

**TOIP** *Pty*  
*Ltd*  
*Telemetry Over Internet Protocol*

# **YDOC RTU**

## **Setup and Configuration**

Version 4.9B5  
February 2025  
Copyright TOIP Pty Ltd

# Contents

1	Introduction.....	6
2	Model Numbers and Ordering.....	7
2.1	Breather Vent.....	8
2.2	Antenna.....	8
2.3	Mounting.....	9
2.4	Cable Entry.....	9
2.5	Accessory Port.....	10
2.5.1	Camera.....	10
2.5.2	GPS Module.....	11
2.5.3	Satellite Module.....	11
2.5.4	TFT Display Cover.....	12
2.6	Expansion Boards.....	13
3	Setup and Configuration.....	15
3.1	Unpack and Check Contents.....	15
3.2	Prepare Case for Cable Glands and Vent.....	15
3.3	Power Board (Cover) Connection.....	16
3.3.1	LFP Cover.....	16
3.3.2	DC Cover.....	17
3.3.3	PV Cover.....	17
3.3.4	NIMH Cover.....	17
3.3.5	LI and DC-LI Cover.....	18
3.3.6	AL Cover.....	18
3.3.7	SLA Cover.....	18
3.3.8	TFT Display Cover.....	19
3.4	Sensor Connection.....	20
3.5	SIM Holder.....	21
3.6	Memory Card.....	22
4	Configuration.....	23
4.1	Terminal Setup.....	23
4.1.1	YDOC Terminal on PC.....	23
4.2	YDOC Terminal for Android App.....	23
4.3	USB Password Activation.....	25
4.3.1	Setting an Admin Password.....	25
4.3.2	Setting a User Password.....	25
4.3.3	Clearing the USB Password.....	26
4.4	Device Configuration Menu.....	26
4.4.1	Viewing Current Values.....	27
4.4.2	Suspending Logging.....	27
4.5	Check Firmware Version.....	28

4.6	General Settings.....	28
4.6.1	Setting the RTU Name.....	28
4.6.2	Setting the Logging Interval.....	28
4.6.3	Reading Time Alignment (Logging at 00:00).....	29
4.6.4	Low Voltage Shutdown.....	30
4.7	Setting the Time and Time Zone.....	30
4.7.1	Time Zone.....	30
4.7.2	Setting the Time.....	31
4.8	Modem Settings.....	32
4.8.1	Network.....	32
4.8.2	Technology.....	32
4.8.3	Provider PLMN Code.....	33
4.8.4	Provider Selection.....	34
4.8.5	Access Point Configuration.....	34
4.8.6	Internet Protocol Version.....	34
4.8.7	Firmware Customisation.....	35
4.8.8	Signal Strength Tests.....	35
4.8.9	APN Login Test.....	36
4.9	Selecting the Server for Data Transfer.....	36
4.9.1	YDOC Native Data Format.....	36
4.9.2	Set the connection interval.....	38
4.9.3	Set the Send Delay.....	38
4.9.4	Sending via TCP.....	39
4.10	Sending Data via FTP.....	40
4.11	Sending Data Via MQTT.....	42
4.12	Sending Data via <i>HTTP</i> .....	44
4.13	Sending via Email.....	45
4.14	Sending via <i>WiFi</i> .....	46
4.15	Starting the Logger.....	47
5	Sensor Configuration.....	48
5.1	GSM Signal Strength Monitoring.....	48
5.2	Adding Internal Sensors.....	48
5.3	Adding Analogue Sensors.....	49
5.3.1	Voltage Sensors.....	49
5.3.2	4-20mA Sensors.....	50
5.4	Adding Pulse Inputs.....	51
5.4.1	Rain Gauges.....	52
5.4.2	Flow Meters.....	53
5.4.3	Pulse Output Wind Speed Sensors.....	54
5.5	Adding SDI-12 Sensors.....	55
6	Calculated Channels Formulas and Aggregates.....	57

6.1	Creating Formulas and Averaging (Max, Min, Avg, Sum)	57
6.1.1	Adding a Calculated / Derived Channel	57
6.1.2	Example Calculations	59
6.2	Using Aggregate Channels	65
6.2.1	Aggregates and Totalisers	66
6.3	Testing SDI-12 Sensors	67
6.4	Powering High Current Drain Sensors	68
6.4.1	SLA Power Board	68
6.4.2	External Relay	68
6.4.3	ML-OP-524 Expansion Board	69
6.5	Setting up Alarms	69
6.5.1	Setting up an Alarm SMS	70
6.5.2	Setting up an Alarm Email	71
6.5.3	Using the Alarm Output	73
7	Saving and Uploading Configurations	76
7.1	Saving an RTU Configuration	76
7.2	Loading a Configuration to an RTU	76
8	Accessories and Expansion Boards	77
8.1	Setting Up a Camera	77
8.1.1	Sending via FTP	79
8.1.2	Camera Troubleshooting	80
8.1.3	Displaying Images in YDOC Insights	81
8.1.4	Image Location on PC	81
8.2	Using Iridium Satellite Modems	82
8.2.1	Satellite Plan	82
8.2.2	Normal and Compacted Mode	83
8.2.3	Hardware Mounting	83
8.2.4	Connection to Telemetry Unit	84
8.2.5	RTU Configuration	86
8.2.6	Testing in RTU	87
8.3	Using the GPS Receiver	89
8.4	Adding an NMEA Compatible GPS	90
8.5	Expansion Boards	91
8.5.1	ML-OI-AD-80MV - Dual channel 16-bit differential input	92
8.5.2	ML-OI-AD-2000MV - Dual channel 16-bit differential input	93
8.5.3	ML-OI-AD-10V - Quad channel 16-bit single ended input	93
8.5.4	ML-OI-AD-20MA - Quad channel 16-bit single ended 4-20mA input	94
8.5.5	ML-OI-BARO - Atmospheric pressure & temperature sensor	94
8.5.6	ML-OI-COM-UART - Serial sensor input (UART)	95
8.5.7	ML-OI-COM-RS232 - Serial sensor input (RS232)	95

8.5.8 ML-OI-COM-RS485, Serial sensor input (RS485).....	96
8.5.9 ML-OI-COM-SDI12 - SDI-12 sensor input.....	96
8.5.10 ML-OA-RS232 - RS232 Auxiliary board.....	97
8.5.11 ML-OU-BLE - Bluetooth LE user interface.....	97
8.5.12 ML-OC-W2P - Waveform to digital pulse converter.....	98
8.5.13 ML-OP-524 – 300mA DC-DC Converter.....	98
8.5.14 ML-OA-WIFI - WiFi Expansion Board.....	100
8.5.15 ML-OI-AX-DS18B20 4x 1-Wire Digital Thermometers.....	101
9 Other Functions.....	103
9.1 Erasing an RTU Configuration.....	103
9.2 Changing the Order of Parameters.....	103
9.3 Exporting to Sentek IrriMax.....	104
9.4 Manual Download.....	105
9.5 Firmware Upgrade (Direct Connected).....	106
9.6 Remote access and upgrades.....	106
9.6.1 Remote Access via TCP.....	107
9.6.2 Scheduled Remote Connections.....	108
9.6.3 Remote Configuration Updates.....	110
9.6.4 Remote Firmware Updates.....	110
9.6.5 Recovering After a Failed Upgrade.....	111
10 Setup for Specific Sensors.....	112
10.1 Rika RK510 Soil Moisture Sensor.....	112
10.2 Rika RK520 Soil Moisture Sensor.....	115
10.3 Analogue Level.....	118
10.4 Aquamonix/Pentair PT05.....	119
10.5 InSitu LevelTroll 400.....	120
10.6 Leeg LMP633 4-20mA 2 wire.....	121
10.7 Sentek EnviroSmart Sensors.....	122
10.8 Testing MODBUS Sensors.....	123
11 Diagnostics.....	125
11.1 Diagnostic LEDs.....	125
11.2 Check Power Supply.....	125
11.3 Modem Diagnostics.....	126
11.4 Connection Issues.....	127
11.4.1 YDOC Terminal Session Errors on Connection.....	127
11.5 Diagnostic Messages in the log file.....	128

# 1 Introduction

This manual has been written to cover the MLx17 family of remote telemetry units (RTUs) manufactured by Your Data Our Care (YDOC). The primary unit is the ML417 with the 4 designating 4G communications. The ML017 (which has the modem module removed) may be ordered for either stand alone logging applications, or when a satellite or WiFi modem is being used.

The RTU has 8 GB of on board storage, provided through a Micro-SD memory card (located beneath the SIM card).

A USB interface is provided on the main printed circuit board and is used to program the unit, to issue commands (to facilitate sensor testing) and to check the signal strengths and perform diagnostic checks on the mobile data connection.



## 2 Model Numbers and Ordering

When ordering your YDOC RTU, first decide what model you will need and the options that may be purchased with it:

<b>MLx17</b>	YDOC MLx17 family of RTUs
<b>MLA417ADS</b>	SDI-12/RS232/RS485, Pulse, Analogue, Accessory for 3G 850 and 4G 850/900 (Available on custom order only)
<b>ML417ADS-M1</b>	SDI-12/RS232/RS485, Pulse, Analogue, Accessory, Universal Cat M1 modem
<b>ML017ADS</b>	SDI-12/RS232/RS485, Pulse, Analogue, Accessory, without modem (for use with WiFi, expansion board, Iridium and Swarm satellite modem)

Other versions (e.g. 3G, pulse only, analogue only, pulse-digital only) are available on request. Contact TOIP for part numbers and minimum quantities.

Then select the required power source / charge board combination:

<b>Cover</b>	<b>Description</b>
<b>AL</b>	Front cover for 3 off D sized alkaline cells
<b>DC</b>	Simple cover for use with external battery backed DC supplies (solar or mains).
<b>DC-LI</b>	Front Cover with DC Regulator and single use Lithium battery.
<b>LI</b>	Front cover with holder for Lithium Battery (non rechargeable)
<b>3LI</b>	Front cover with holder for up to 3 Lithium Battery (non rechargeable)
<b>LFP</b>	Cover for 1 to 4 off 18650 LIFEP04/LFP batteries.
<b>PV</b>	Front cover with integrated solar panel and a single 3AH 26650 size LIFEP04/LFP rechargeable cells.
<b>SLA</b>	Charge Board for SLA or LiFEPO4 / LFP batteries
<b>TFT</b>	Front cover with built in TFT display. This model

makes use of the Power board from the DC Cover

## 2.1 Breather Vent

To avoid build up of moisture in the case, the telemetry units should be fitted with a breather vent. A 6mm vent is supplied with the YDOC units. But if you are using your own enclosure, you should install a 6mm or 12mm breather on the top of the case.

<b>BVENT-M6</b>	Breather vent M6 (for use with YDOC Case)
<b>BVENT-M12X15</b>	Breather vent M12 x 15mm (for use with larger cases)



## 2.2 Antenna

The RTU is fitted with a PCB mounted antenna for the mobile data modem. This antenna will be sufficient for installation on sites with good mobile coverage. For sites with poor reception an external antenna should be fitted.

A "UFL" antenna socket is provided on the main PCB for the external antenna. As most antennae utilise an SMA connector, you will need a UFL to SMA adaptor cable: the UFL end is plugged into the socket and the SMA end mounted on the bottom of the case. When using an external antenna, change the position of the Antenna Jumper on the main board from INT to EXT. If you order the option YDOC-UFL with your RTU, the case will be drilled to suit the bulkhead mounting SMA socket. If you order the adaptor separately you will have to drill the case and fit the adaptor yourself.

When using the internal antenna you should use YDOC's plastic post mounting bracket as the metal one may interfere with the signal from the internal antenna.

**YDOC-UFL** SMA to UFL adaptor cable  
100mm



**GIDM70T-SM-xx** Antenna 4G700 5.1 dBi cable  
and SMA male connector  
( xx=02 2m cable, xx = 05 5m  
cable)



## 2.3 Mounting

The RTU can be mounted directly on a wall or face plate.  
A post mounting kits is also available:

**YDOC-PMK** Post mounting kit plastic for  
YDOC ML315. Includes mounting  
plate, hose clamps and 4 off  
6mm bolts & nuts



## 2.4 Cable Entry

The YDOC RTU cases are supplied without any holes drilled in them. Each case is shipped with a template which can be used to mark and drill the holes for cable glands to be fitted. If you require a number of units all with identical cable entry, YDOC offers a laser cutting service wherein the cases will be supplied with the holes pre-cut.

The standard cable glands are size M12 and will accept cables in the range 3 to 6mm. If you are going to use cables more than 6mm in diameter, you will need to obtain larger M16 cable glands.

**GLANDM12-X** Drill and fit M12 cable glands. X = 1, 2, 3, 4



Should you wish to bring the USB port to the outside of the case, a bulkhead mounting waterproof USB socket is available. This allows the unit to be configured without having to open the case.

**YDOC-USB** Bulkhead mounting USB Mini connector



As an alternative to cable glands, the case can be fitted with 5 pin sockets and the sensors fitted with the matching 5 pin plugs.

**YDOC-CON5P** 5 pole Waterproof connector for sensor connection: plug and socket



## 2.5 Accessory Port

The MLN417-ADS RTU includes an additional serial port which is used to connect a variety of accessories.

### 2.5.1 Camera

The YDOC RTU may be used to capture regular still images from a remote monitoring site. Although YDOC manufactures a low res and high res camera, only the high resolution unit is currently on offer in Australia.

The RTU must be fitted with a SIM card with a sufficiently high data allowance (typ 20 MB per month).

When using the Accessory Port, you will require the LFP or SLA power board with either a 2W or 5W external solar panel or external DC power source.

**YD-CAM-2.0M-xx**      Digital Camera 2MP with IR LED's for night time use (to 20m)  
xx=60 – 60 degree lens  
xx=90 – 90 degree lens



## 2.5.2 GPS Module

A GPS Receiver option is also available on the ML315 ADS loggers. The GPS Receiver is a separate waterproof module which mounts outside of the RTU case and connects via cable (and cable gland) to the Accessory Port on the ADS version RTU.

**YDOC-GPS**      GPS Receiver for ML315ADS Telemetry Unit



Note that the GPS Receiver needs to be mounted on a suitable plate. TOIP can supply a small mounting bracket for this purpose or you can make your own.

## 2.5.3 Satellite Module

An External Satellite Modem may be fitted to provide communications at sites where no mobile data coverage is available. This option is only available on units which carry the Accessory Port (e.g. ML417ADS). The modem is an Edge unit manufactured by Iridium.

**EDGE**      Iridium Edge satellite modem for ML417ADS Telemetry Unit



### **ENC-ABS**

ABS Enclosure 180 x 180 x 110mm  
with 5W solar panel 3AH battery



Although YDOC specifies the 5V version of the Iridium modem, this is not readily available in Australia and the 12V version should be used in its place. This requires use of an external 12V solar power supply (which can be sourced from the SLA charge board).

Be careful to check that your intended application will fit within the data allowance of your satellite provider. Most Iridium plans only allow for 30 kB per month, which restricts you to a couple of readings per day from one or two sensors. YDOC offers a compressed data mode which reduces data volumes but only allows up to 15 parameters to be sent. In compressed mode, you must use single character Codes (P1 to P15) for the various parameters.









### **2.5.4 TFT Display Cover**











The TFT Cover has an integrated TFT display which is used to display the current readings from the sensors.



## 2.6 Expansion Boards

The ML417 units are fitted with an expansion port in to which one or more Expansion boards may be connected. These allow you to add more features or input channels to the RTU. Boards can be stacked on top of one another, but only one of a given type can be used.

<b>ML-IO-AD-80MV</b>	Com Port Expansion board 2 x 16 bit differential amplifier 10/20/40/80mV	
<b>ML-OI-AD-2V</b>	Com Port Expansion board 2 x 16 bit differential amplifier 0.25/0.5/1/2V	
<b>ML-OI-AD-10V</b>	Com Port Expansion board 4 x 0-10V	
<b>ML-OI-AD-20MA</b>	Com Port Expansion board 4 x 4-20mA channels	
<b>ML-OI-BP</b>	Com Port Expansion board for YDOC MLN417 RTU – Barometric Pressure Sensor	
<b>ML-OU-BLE</b>	Expansion Board Bluetooth LE for Wireless comms to RTU	
<b>ML-OI-OP-524</b>	Expansion Board to provide 12V power source for external sensors. 5V@300mA, 12V@200mA, 24V@100mA	
<b>ML-OI-AX-DI</b>	Adds 4 off digital/pulse inputs	
<b>ML-OI-AX-DSB18B20</b>	Allows connection of up to 4 off 1 wire digital temperature sensors (thermistors) of type DSB18B20	

<b>ML-OI-AX-RH</b>	Supports connection of an external 1 wire relative humidity sensor of type AM2315/T9602D3/SHT3X	
<b>ML-I-COM-UART</b>	For connection of TTL serial sensors	
<b>ML-OI-COM-RS232</b>	Supports connection of a GPS if the Accessory port is already in use or not fitted	
<b>ML-OI-COM-RS485</b>	Provides an addition RS485 port for connection to RS485/MODBUS sensors	
<b>ML-OI-COM-SDI</b>	Provides an additional SDI-12 port	
<b>ML-OA-RS232</b>	Provides an additional RS232 port for accessories such as a camera	
<b>ML-OA-WIFI</b>	Adds a WiFi connection to the RTU, enabling it to send data via a local WiFi network rather than a cellular connection	
<b>ML-OO-MODBUS</b>	Allows the RTU to send data to an on-site SCADA system	
<b>ML-OO-SW</b>	Adds 4 solid state switch outputs for control of external systems	
<b>ML-OC-W2P</b>	Waveform to pulse converter for interfacing to flow meters and anemometers which provide a passive coil output	

## 3 Setup and Configuration

### 3.1 *Unpack and Check Contents*

On receipt of your logger, check that the contents are complete. The package should contain:

- 1 off ML417 telemetry unit with power board and cover of choice
- 1 off Bag of components
  - 4 off case screws, 4 off cable glands, 3 off input connector headers (1 off 3 pin, 1 off 4pin, 1 off 6 pin) 1 off template, 1 off power connection lead, breather vent

### 3.2 *Prepare Case for Cable Glands and Vent*

The case is supplied without any holes drilled in it. You will need to drill the case to take the breather vent and cable glands:

- Undo the 4 #1 Torx screws holding the Main PCB to the case and carefully remove the PCB. Place it inside an anti-static bag
- Determine how many cable glands are required
- Lay the template down on the bottom of the case (the blue part)
- Line the template up so that the edge closer to the printing sits against the raised edge of the case
- Using a scribe or spring loaded centre punch, mark the position for the centre of the holes
  - Use hole 2/3 for a single gland; use holes 1/3 and 3/3 for 2 glands; use holes 1/3 2/3 and 3/3 for 3 glands and use holes 1/4 through 4/4 for 4 glands
- Drill a pilot hole using a 3mm drill bit
- Carefully drill the holes out to 12mm (cable glands) or 6.5mm (external antenna) using a step drill. Step drills are preferable to twist bits as the latter tend to stick and pull through the case, distorting the hole
- To fit the breather vent, turn the case over, lay the template on top, then repeat the process of drilling a 6.5 mm or 12mm hole in the top
- Fit the cable glands and breather vents into the holes and secure with lock nuts
- Clean out any plastic debris from inside the case
- Re-fit the Main PCB
- Check that the logger is functioning properly.

### **3.3 Power Board (Cover) Connection**

The section below describes each power option in detail.

The PV cover has a small solar panel on the lid whereas the SLA, NIMH, LI and DC covers are flat. The TFT lid houses the TFT display and a DC power board with rechargeable LFP cells.

Each power supply board connects to a matching connector on the Main printed circuit board (PCB) using a 100mm Power Connection lead (the YDOC ML-PSC cable).

Plug one end of the Power Connection lead to the 2 pin socket marked X3 on the power PCB and the other end to the matching socket on the Main PCB marked X15.

#### **3.3.1 LFP Cover**

The LFP cover will be supplied as the default power option.

It can be fitted with 1 to 4 18650 size LiFePO<sub>4</sub> (LFP) batteries. These have a 3.2V output and capacity of 1.5AH. A single cell 1.5AH gives 4.8VA of capacity, and 4 cells yields 19 VA. The cells are connected in parallel rather than series, which makes battery management much easier.

The power boards are designed to be used with LFP (LiFePO<sub>4</sub>) batteries only. LFP cells have a terminal voltage of 3.2V and are much safer than Li-ion cells: the electrolyte in Li-ion cells is an oxidant and if the cells overheat they can catch fire and are extremely difficult to extinguish, as they do not need an external source of oxygen. Li-ion cells also have a terminal voltage of 3.6V. When sourcing cells be careful that you do not use Li-ion cells in the LFP and PV covers.

A link on the board allows you to choose whether it is being used with 12 cell (7.2V OC) or 36 cell (18 to 21V OC) solar panels. Setting the link to 12 cell with the higher output cells will have the unit switching from trickle to high charge at a lower panel output, helping maximise the charge into the batteries.

### 3.3.2 DC Cover

The DC cover or DC board on its own, can be used on systems where you have an alternative source of battery backed power, such as a 12V solar recharge unit. There is no storage on the power board and only use it if you know your external source has reliable battery pickup.

Connect the external source to the header on the PCB, then check that you have 3.6V on the output to the RTU.

### 3.3.3 PV Cover

The PV cover is designed for use with a single 26650 size 3.2V / 3AH LFP/LiFePO4 battery. This sits in a holder on the power board and can be secured in place with a cable tie.

The external power source (9V to 30 V DC) connects to the two pin header labelled X4. Wire the connector as follows:

Pin 1	Power
Pin 2	Ground

### 3.3.4 NIMH Cover

The NIMH Cover must be fitted with 3 off 2500 mAH NiMH batteries. The batteries in these covers yield 5 VA of stored energy. These are installed in the plastic holder in the base of the lid. Follow the polarity markings on the inside of the battery holder.

Due to the high current requirements of the modem, make sure that you purchase high quality, name brand cells: cheap cells will not be able to hold their terminal voltage under high load conditions (which will be evident as not being able to access the modem).

The external power source (9V to 30 V DC) connects to the two pin header labelled X4. Wire the connector as follows:

Pin 1	Power
Pin 2	Ground

**IMPORTANT:** If you have selected the DC-NIMH power options and are going to leave the YDOC turned off for more than a couple of days, you

MUST remove the batteries from the holder. Otherwise the batteries will go flat and will lose capacity. They will then need to be rejuvenated by putting them through multiple charge-discharge cycles in a suitable NiMH charger.

### **3.3.5 LI and DC-LI Cover**

The LI and DC-LI must be fitted with a suitable battery:

SAFT	LSH-20	3.6V D 13AH	Spiral Wound
GEBC	ER34615M	3.16V D 13AH	Spiral Wound

The 3LI cover accepts up to 3 of these cells.

The DC-LI cover must be connected to a plugpack with a 12V 1A output.

The external power source connects to the two pin header labelled X4.

Wire the connector as follows:

Pin 1	Power
Pin 2	Ground

### **3.3.6 AL Cover**

The AL Cover is designed to operate from a set of 3 off D sized alkaline batteries. Please ensure that you only use high quality brand name cells (Duracell, Energizer). It may also be used with the LI and 3LI covers. Use the YDOC Battery consumption calculator to calculate expected battery life for the cells in this unit.:

<https://www.ydoc.biz/datalogger-power-consumption.html>

### **3.3.7 SLA Cover**

The SLA cover requires a solar panel with a nominal open circuit voltage (OC) of 21V. Although you can use solar cells with a lower OC voltage, they will not commence charging the battery until much later in the day and will stop charging earlier in the day.

You will need to drill the SLA cover to fit a cable gland for the solar panel and another for the connection to the battery. Alternatively you can fit the YDOC PCB, the SLA board and battery into a larger enclosure.

The minimum battery size for the SLA charge board is 12V 3AH. TOIP can supply a 12V 3AH LiFePO<sub>4</sub> (LFP) battery pack. A 4 cell 3AH LFP battery pack yields 38 VA, whilst a 7AH SLA cell yields 84 VA.

The battery signal is available via a low voltage protection switch on pins 3 and 4 of the OUT socket. This can be used to power sensors which require permanent power. From version 1.4 on, the PCB uses a 7 pin header for the OUT terminals. Pin 6 is the Control (CTL) signal and can be fed from the switched DC voltage on the RTU PCB (X4 pin 1). This then turns on the switched 12V output which can provide up to 2A of current on pin 6 of the header.

The MON signal may be connected to one of the two Analogue voltage inputs to monitor battery voltage (X1 Pin 3 or X1 Pin 4).

### 3.3.8 TFT Display Cover

The TFT display is used to display the current readings from the sensors. The RTU fitted with the module may be powered as follows:



- from the ML-PB-DC power board which takes 8-24V DC in and provides a regulated output for the RTU
- using any of the other power boards (LFP, NiMH etc) which may be mounted on the back of the display board and which hence fit inside the standard cover
- from the 12V switched output on an SLA charge board. In this case the display must be removed from its cover and mounted on or inside the enclosure.

The display must be connected as follows:

- 5 pin connector fits to Accessory Port X5 on YDOC PCB
- 4 pin connector goes to Digital inputs via Port X3 on YDOC PCB
  - Digital Input 1 is used for the pushbutton switch which signals the display to wake. If you are already using Digital Input 1 for another sensor, you must move it to Digital 2 or 3 as the display functionality must use input 1.

Open the configuration menu and under the Accessory Port section select Option 1, Display. The YDOC will automatically add the switch to Digital 1.

The display will automatically power down 1 min after use. You can alter this time under option 3.

After connecting the display, press the switch and check that the green AC LED turns on, indicating that the display is powered.

The sensor tags will display in the order set under the Parameter Order option on the RTU. To change the order:

- activate the menu and select 4 Parameter Overview
- when the Parameters menu opens, select 2 Parameter Order
  - a list will display showing the parameters in their current order
- now choose the number alongside the number of the parameter you wish to change
- the unit will then ask you to enter the new position for that tag/parameter
  - if you were changing the position of the 4<sup>th</sup> parameter so it would be first in the list, you would select 4 then 1.

### 3.4 Sensor Connection

The picture below shows the location of the input connectors on the RTU. The yellow dot marks Pin 1 of each socket (always to the left).

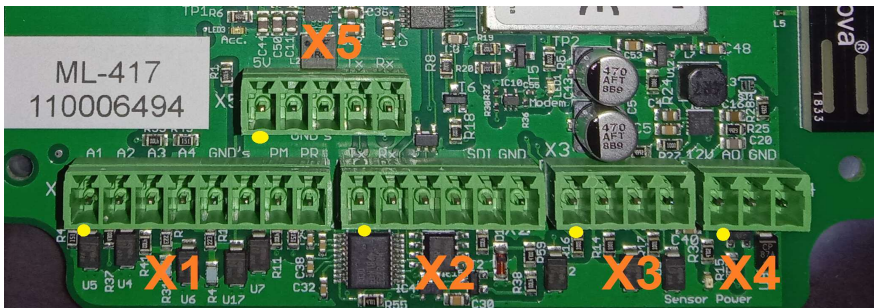

Connector	Pin	Function
<b>X1 (Analogue)</b>	1	AN1 0-20mA
	2	AN2 0-20mA
	3	AN3 0-10V
	4	AN4 0-10V
	5	Ground
	6	Ground
	7	AN5 Resistance
	8	AN5 3.3 V Reference
<b>X2</b>	1	RS232 Tx

<b>(Serial)</b>	2	RS232 Rx
	3	RS485 A (+)
	4	RS485 B (-)
	5	SDI-12 Data
	6	Ground
<b>X3 (Digital)</b>	1	Pulse input (Rain) 1
	2	Pulse input (Rain) 2
	3	Pulse input (Rain) 3
	4	Ground
<b>X4 (12V Power)</b>	1	12V Sensor Power (Switched)
	2	Alarm Output (Open Collector)
	3	Ground
<b>X5 (Accessory)</b>	1	Switched 5V DC
	2	Ground
	3	-
	4	Tx
	5	Rx

Locate the headers for the connectors and fit the sensor wires to the corresponding pin on the header.

If your application requires permanent sensor power or current higher than that available on the switched 12V output on X4 Pin 1, use the SLA charge board which has both permanent and switched high current (2A) outputs available.

### 3.5 SIM Holder

The RTU requires a SIM with a data plan in order to operate. A 5MB per month plan is sufficient for most applications.

The SIM holder is located on the middle left of the main PCB. Slide the SIM into the holder: the square edge goes in and the notched edge should face out. Ensure PIN request is turned off on the SIM card.

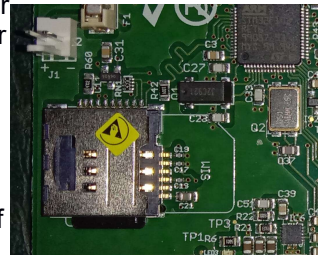

The Cat M1 YDOCs require a Cat M SIM Card (Telstra IoT Data Plan). You can also use SIMs from international roaming providers such as 1NCE. 1NCE SIMs can only be used on the LTE-M / Cat M1 service. If you select either NB IoT or LTE/NB IoT, the cards will not register to the network.

### **3.6 Memory Card**

At the lower edge of the SIM holder you should also see the edge of the Memory Card. For maximum reliability, the units use “Industrial Grade” cards, not the cheaper “Consumer Grade” cards. Consumer grade cards have a shorter life and lower temperature rating.

The RTUs are fitted with an 8GB Micro SD card. Push the card in to unlock it. You can then place the card in a Micro Card adaptor, plug the adaptor into an SD card slot or SC card reader and view the card’s contents. Under normal circumstances you will never have to remove the Micro SD card.

But can give issue if the RTU is exposed to prolonged low battery conditions. This may show up as Write Errors in the logs or as the RTU power consumption suddenly increasing. If you see these errors, you can format the card from the Maintenance Menu (or from a PC). If it still gives errors, replace it.

When replacing the card, remember to note that it is installed with the contact pins facing upwards.

## 4 Configuration

The RTU is configured using the USB interface on the centre of the main PCB (Mini USB connector). If you wish to be able to access the programming port without opening the RTU, fit the external USB connector or the Bluetooth Expansion Board.

### 4.1 Terminal Setup

#### 4.1.1 YDOC Terminal on PC

You can use the YDOC Terminal program or any other terminal emulator to configure the units. YDOC Terminal has some additional functionality such as a button to take a test picture from an attached camera. The latest build of YDOC Terminal can be downloaded from:

<http://www.your-data-our-care.com/datalogger-utilities.html>

Plug a Mini USB cable into the socket on the RTU

- Windows should detect the unit and try and install a serial port driver
- If not check that the unit has been recognised in Control Panel / Device Manager
- you may also wish to uninstall YDOC Terminal and, with the RTU connected, install it again to make sure the serial port drivers are loaded.

Set Up HyperTerminal or YDOC Terminal:

- Settings 19200/8/N/1
- COM Port Number: as identified in Device Manager
- Connect to the RTU

### 4.2 YDOC Terminal for Android App

After installing the Blue tooth LE expansion board (ML-OU-BLE) as per section 8.5.11 you can communicate with the RTU over the Bluetooth interface on your Phone or PC.

Download the YDOC Terminal App from the Play Store and install it on your Android Smart Phone. To connect to the RTU:

- open the App

- click on the **BLE SCAN** button
- the RTU will scan for local bluetooth devices and show a list of the ones it finds

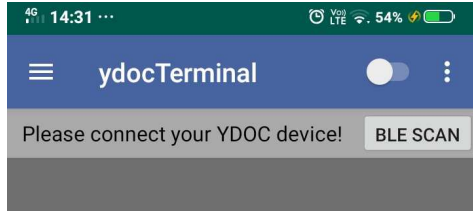

- select the RTU using the RTU name to identify it
- the APP will connect to the RTU and show the current status

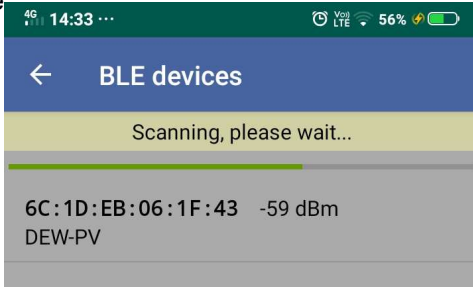

- click on the spanner icon to activate the menu
- the main configuration menu will open

- activate your device's keyboard and type the number next to the option you wish to select i.e. 3 for Configuration Setup
  - if you are selecting a text option, make sure you use the lower case rather than upper case character e.g. "d" not "D"

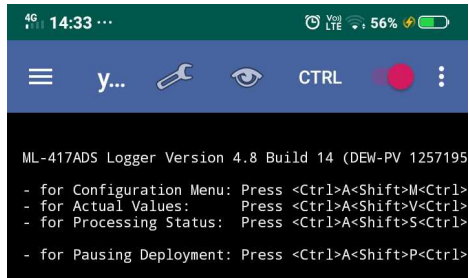

- you can now configure the RTU in exactly the same way as shown using the PC based YDOC Terminal program.

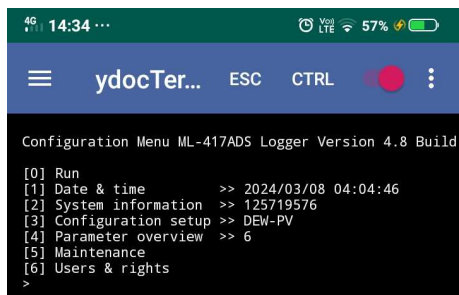

**WARNING:** Do not use the Bluetooth Expansion Module without activating the USB Password. Failure to do so may leave the unit vulnerable to connections from unauthorised users who manage to scan for Bluetooth connections when close to the RTU.

## 4.3 USB Password Activation

For added security, the YDOC RTUs allow you to set a Password which must be entered before users can access the Menu interface.

You can set an Admin password and one for lower level Users

- Admin users have full system access
- Users can then be given access to a subset of the functionality.

### 4.3.1 Setting an Admin Password

If you want to use USB Password Protection, activate it from the main menu:

- connect to the YDOC using YDOC Terminal
- activate the menu
- from the Configuration Menu select **6** Users & Rights
- at the Users and Rights Menu, select **1** User Login
- then select **1** to enable User Password control
- when prompted, type in the password and press ENTER
- enter the password a second time to confirm it.

### 4.3.2 Setting a User Password

Once you have set an Admin password, you can set a password for lower level users:

- after setting the Admin Password, go to the Users and Rights menu and select **4** Operator Password
- when prompted set the password to use for the Operator
- the Operator Rights menu will then display
  - for each of the 5 functions shown, select whether the Operator will have access to this function. The default for each is 0. Set the value to 1 to enable the Operator to use this function

- Configuration Edit: Allows the operator to change the configuration
- Parameter Edit: Allows operators to change the order of parameters
- Parameter View: Allows operators to view the parameters
- Data Download: Allows user to download data from the RTU
- Firmware upgrade: Allows users to upgrade the RTU firmware.

### 4.3.3 Clearing the USB Password

If you have lost the USB Password, or if has been set accidentally, you can erase it as follows:

- open the RTU and disconnect the power cable
- remove the Micro SD card
- place the card in a Micro to USB adaptor and load it into an SD slot on your PC
- using a text editor (e.g. Notepad ++ ) create a blank text file with the name "erase.cfg" and save it in the root directory of the card,
- remove the Micro SD card and place it back in the RTU
- re-connect the power cable
- when the RTU restarts, the USB password will be cleared.

## 4.4 Device Configuration Menu

If the screen is blank, press the Enter Key.

To activate the command interface:

- click on the **Show Configuration Menu** button at the top of the screen
- if the RTU has just been powered up, you may see a row of dots on the screen as it goes through its startup process
- or Press the following key sequence: **Ctrl a, Shift m, Ctrl d**
  - Although the menus display letters in upper case, the menu options only respond to lower case characters. So when the RTU says to press **Ctrl + A**, you must actually press **Ctrl + a**



The Configuration Menu will then display.

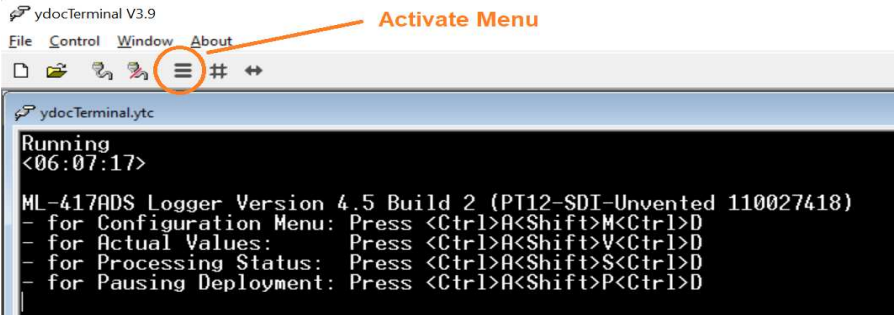

### 4.4.1 Viewing Current Values

When the RTU is in Run mode, you can display the last valid reading from the connected sensors as follows:

- click on the hash icon or type `Ctrl+a Shift+v Ctrl+d`

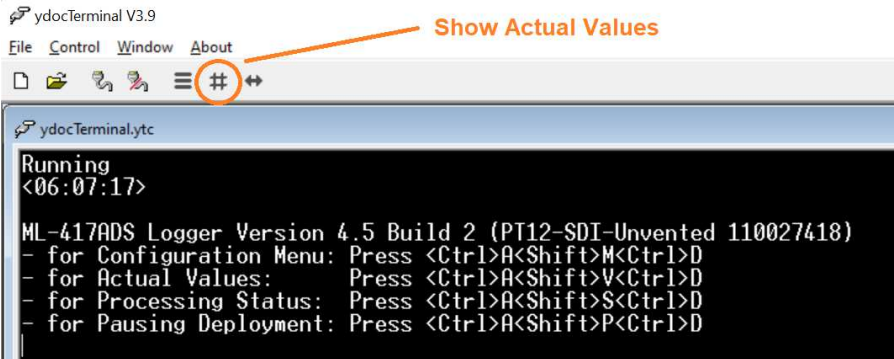

### 4.4.2 Suspending Logging

Normally, after a period of inactivity or if the connection to the RTU is dropped, it will revert to Run modem. When the RTU is in Run mode, you can check the current status and force it to stop logging and go in to the "Pause" state as follows:

- to display the status `Ctrl+a Shift+s Ctrl+d`

- the current status of the RTU and the various process it runs will be shown on screen
- take note of any error messages which could indicate a potential problem
- To suspend logging    Ctrl+a    Shift+p    Ctrl+d
  - the RTU will switch to Pause mode
  - the RTU will not revert to Run mode until you specifically set it to Run again

## **4.5 Check Firmware Version**

With the Configuration Menu on screen, the first task you perform should be to check the firmware version to make sure the unit has the latest issue.

The firmware can be downloaded from the YDOC web site:

<http://www.your-data-our-care.com/datalogger-firmware.html>

For detailed instructions on how to upgrade the firmware, refer to section: 9.5 .

## **4.6 General Settings**

This menu option allows you to set the RTU Name and time zone.

From the Configuration Menu, select    **3**    Config Setup press    **3**

Then select the    **1**    General Setup Menu

### **4.6.1 Setting the RTU Name**

From the General Settings Menu select    **1**    Device Name

Give the unit a name e.g. the Site Name and press Enter

#### **Note:**

- DO NOT use underscore (“\_”) characters or spaces in the Name as these will block the transfer of data to Sensori
- It also pays to keep the name short to reduce the length of the file name.

### **4.6.2 Setting the Logging Interval**

The logging interval must be set to match the application: 15 minutes is typically used for soil moisture and weather monitoring. Sensors can be set to be recorded at the default log interval or at a different rate e.g. climate sensors at 15 min, water level at 4 hr.

From the General Settings Menu, select 2 Data Log Interval

- You can then select the logging rate to be used in Normal Mode (1) and in Alarm Mode (2)
- By default, Alarm Mode is de-activated (shows as Not Used)
- If for instance you were monitoring stream height and wanted to increase the frequency of logging once the level exceeded a set threshold, you would enter the higher rate in the Alarm Mode
- the unit will go in to Alarm mode once the threshold is crossed and stay in that mode until it goes below this by the amount specified in the Hysteresis setting for the alarm.

After selecting an option (1 or 2), you will be prompted for the time units: select 1 for seconds, 2 for minutes or 3 for hours

- After pressing enter you will be asked to select the period from the list of available times
  - For 15 minute rate select 2 for minutes then 1 for 15
- At the menu press 0 to go back to the previous menu level.

### 4.6.3 Reading Time Alignment (Logging at 00:00)

With the default settings, the RTU will time stamp the readings at the time the reading is completed. A log of SDI-12 data which started at 09:00 and took 33 seconds to finish would be time stamped as 09:00:33. This can be a problem when comparing data between sites or if you have multiple SDI-12 sensors.

The Time Stamp Round Down function allows you to ensure that all readings within the specified time range, will have the same time stamp.

The Time Stamp Round Down interval must be an Integer fraction of the Log Period e.g. with a 15 minute log period, use 30 sec, 1, 3 or 5 min.

To activate Time Stamp Round Down:

- under General Settings, select option 3 Time Stamp Round Down
- then, enter the round-down value
  - for 15 minute logging, you can use a value of 1 min, 3 min or 5 min, are all factors of 15
  - for 10 minute logging, you can use a value of 1 min, 2 min or 5 min

- note that if the Round Down value is not a factor of the Logging Rate you will see incorrect time stamps: for instance if you use 10 min logging with a round down of 3 minutes (180 sec), your readings will be time stamped at 00:00:00, 00:09:00, 00:18:00, 00:30:00 etc. Here the 10 minute time stamp is rounded to 00:09:00 and the 20 minute value to 00:18:00, which is wrong.

#### **4.6.4 Low Voltage Shutdown**

The RTU monitors the state of the batteries and will shut down when the battery voltage gets below the safe threshold. This value varies according to the power board and hence type of battery being used: for example a 3.6 V single use Lithium battery holds its output capability to below 2.7V, whilst a NiMH rechargeable pack starts to taper off at 3V.

When configuring the telemetry unit you should thus set the Battery Protection setting to match the type of cells being used:

- from the General Settings menu, select option **8** Power Supply Board. Then, when prompted, select the board from the list
- then select **9** Battery Protection and then select **1** to enable the battery monitoring
  - the YDOC unit will then use low battery thresholds appropriate for the type of cell selected.

### **4.7 Setting the Time and Time Zone**

The RTU allows you to set a time zone. Where possible you should use UTC. That way the time will never need to be adjusted at the start and end of daylight savings, which will also mean that you do not lose an hours data at these times. The offset to local time should be applied in the presentation software

- If you are sending data to the Sensori platform, please set the RTU clock to UTC and the time zone to UTC+0
- The time zone will then be set for each RTU within Sensori and adjustment made to the data when it is viewed, according to the time zone selected for that specific user.

#### **4.7.1 Time Zone**

If however you want to set the unit to local time, you can select the Time Zone for the location in which the RTU will be deployed. If you do this, make sure that in Sensori, you select a Time Offset to cancel this out (e.g.

if your RTU is in South Australia and the time zone is +09:30, in Sensori, set the Time Offset to -09:30)

From the General Settings menu, select **8** Time Zone press

- when using UTC, set the time zone to 0
- if not using UTC, enter the number of hours either ahead or behind UTC e.g. For central Australia i.e. 09:30, enter the time zone as **9.5**

## 4.7.2 Setting the Time

From the Main Menu select **1** Date and Time

When prompted set the Date and time to the current UTC time (set it to the correct local time if you are not using UTC) in the format shown on screen e.g. YY/MM/DD and then hh:mm:ss.

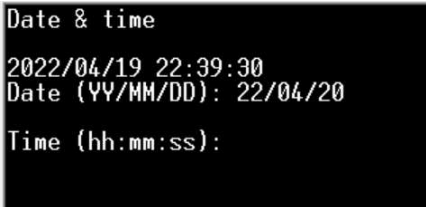

```

Date & time
2022/04/19 22:39:30
Date (YY/MM/DD): 22/04/20
Time (hh:mm:ss):
  
```

To keep the existing value press ENTER.

### 4.7.2.1 Using an NTP Server to Synch the time

You should synchronise the RTU time with a network time server (NTP Server) to ensure that it never drifts appreciably from the nominal time. After synchronising the RTU clock, the RTU will make very small adjustments to the clock frequency to reduce the daily drift.

From the Main Menu:

- select **3** Configuration Setup
- select **3** NTP time update
- turn on the auto time update by selecting **1**
- in the server name enter **1.au.pool.ntp.org**
  - you can also search the Internet for the names of servers in your area
- select the time at which you want the time to be updated:
  - if you have set the time zone to UTC, the update time will be in UTC
  - avoid using a time of 00:00:0 because at that time of day, large numbers of servers try and synchronise their time and the service may time out

- perform a time update test **T**
  - the RTU will turn on the modem, connect to the APN server and then try to synchronise to the NTP server
  - if it fails, double check the server name and try an alternate server.

## 4.8 Modem Settings

To set up the modem, go to the Configuration Menu and select **2**. Make sure you have a SIM card loaded into the SIM holder and that you are in a location with network coverage.

If you are using the internal antenna, the antenna selection plug should be in the INT position; if using the external antenna, set the link to EXT only once you have the external antenna connected.

When changing a Modem setting, always go back out of the modem menu: you will be promoted to save the changes – always select “Y” at this level, then go back to the modem menu to make your next selection.

### **WARNING : Cat M1/NB1 SIM Users and Network registration**

One way that Cat M1 and NB1 devices save power, is to reduce the frequency with which they connect to the network to advise the base station that they are active. As a result, when you first insert a SIM card into a Cat M1 YDOC, the Signal Strength test may fail. If this happens, set to the unit to RUN mode and leave it on the bench for a couple of hours, then try again.

### 4.8.1 Network

The modems support use of either 2G or 4G networks for the Cat M1 and NB IoT services. When using the units in Australia, where there is no 2G service, set the units to 4G only:

- select 1 Network
- select 4 4G only

### 4.8.2 Technology

The units will operate on either Cat M1 or NB 1 / NB IoT

- Cat M1 allows bi-directional data transfer in real time which is required for remote connections and over the air configuration and firmware updates
- NBloT offers a slight increase in range and a reduction in power consumption, but does not offer “live” two way connections – latencies of up to 7 seconds may be experienced between a packet being sent and it being received at the other end
- you can select Cat M1 only, NBloT only or Cat M1 with NB loT fallback and NB loT with Cat M1 fallback

Our recommendation is to use Cat M1 where sufficient signal is available and to only use NB1 / NB loT on sites which are out of Cat M1 range (and where fitting a higher gain antenna and/or elevating the antenna has not worked). To select the Technology:

- select 2 Technology
- select 0 LTE-M (for Cat M1)
  - if you want to be able to use NB loT as a fallback, select option 2 LTE-M – NB loT

If you are using 1NCE SIM cards, the technology must be set to “LTE-M” only. This is because 1NCE’s roaming agreement in Australia is for that service only. Setting the RTUs to NB loT or LTE-M with NB loT fallback result in the units failing to register on the network.

### 4.8.3 Provider PLMN Code

This option allows you to lock the units to a specific network by entering the operator’s PLMN code. You can also view which networks are available. If you are using SIMs from a global provider (1NCE etc) the units can be locked to a network, but must be set to Roaming mode.

To manually set the Provider Code:

- select 3 Provider PLMN Code
- the common provider codes are:
  - Telstra 50501
  - Optus 50502

- Vodafone/TPG 50503
- type in the code e.g. 50501 for Telstra
- the default option is 0, for automatic selection according to the SIM.

#### 4.8.4 Provider Selection

If you are unsure which code to use, allow the RTU to scan for the available networks.

To view the available networks:

- select 4 Provider Selection
- the RTU will scan for the available networks and show a list with their PLMN code. The scan may take several minutes to complete
- enter the number next to the desired provider
- select the preferred provider from the list.

#### 4.8.5 Access Point (APN) Configuration

The APN needs to be set to match the settings give to you by your provider. The default is to have the APN details read from the SIM card. To change the APN settings:

- select Option 4 and the APN sub-menu will open:
- select 5 Managed by SIM Card
  - this will toggle the selection from ON to OFF; if it is already ON it will change to OFF.

If you are entering the APN manually (I.e Managed by SIM Card = OFF):

- Select 1 Access Point Name
- Enter the Name:
  - Telstra telstra.internet or telstra.m2m depending on SIM configuration
  - Vodafone live.vodafone.com
- The APN User Name and Password are normally blank. If you need to change them select the menu option (4 or 5) and enter the details given to you by the provider
- APN Authentication use PAP (plain) unless your provider advises otherwise.

#### 4.8.6 Internet Protocol Version

For many years computers and connected products have used a protocol referred to as "IP4" for networking. As the number of connected devices exploded, the available address range (0.0.0.0 to 255.255.255.255) was

too small to allow future expansion. IP6 was developed to allow a massive increase in the available address range. Although most providers still support IP4, some only allow IP6. IP4 is still the default in Australia but that may change, in which case the option will not be available. If using the RTU where both IP4 and IP6 are available:

- Select 6 Internet Protocol
- select 0 for IP4

## 4.8.7 Firmware Customisation

The modem firmware supports selection of a set of custom settings to support the network in various countries/regions. Within Australia that includes settings of the additional registers which control Cat M1 and NB 1 operation.

Once the RTU has connected and registered on the network, you can set the customisation for Australia:

- Select 7 Customization
- Select 3 Australia (AU)
  - the unit will apply the AU settings
- if you are using an International SIM (1NCE, SimBase)
  - select 2 Global (ROW).

## 4.8.8 Signal Strength Tests

If you have loaded a SIM and completed the above setup, you can perform a signal strength and APN login test:

- Select 5 Signal Strength
  - The screen will display the progress as the modem is enabled and the unit connects to the GSM network

If the signal strength test fails:

- Make sure that you have a valid SIM card: if you are not sure, try it in a mobile phone
- Ensure that you actually are in a location with network coverage
- if you are using a Narrow Band IoT SIM, set the unit to RUN mode and allow it to run for a couple of hours then come back and try again
- Try raising the unit higher to see if you can get signal

- The ML417 is fitted with a PCB mounted antenna
  - The Main PCB has a socket for a “UFL” connector in to which an external antenna can be plugged
  - If fitting an external antenna, shift the Jumper JP3 from the INT to the EXT position
  - You will also need to drill an extra hole in the case through which to pass the UFL to SMA adaptor cable.

If you receive a message that the “Modem is Busy”, wait 1 to 2 minutes for the RTU to complete initialisation then try again.

#### **4.8.9 APN Login Test**

- If the Signal strength test succeeds, you should then perform an APN login test to make sure the unit can connect to the provider’s cellular data service
- From the menu select **T APN Login Test**
- If the APN test fails, double check that you have the correct APN settings. You may also want to check with another device at the same location that it can connect to the APN.

### **4.9 Selecting the Server for Data Transfer**

When sending data to a server, you must select the Protocol to be used (FTP, TCP, MQTT, HTTP, Email) and the format in which the data will be sent (YDOC Native, CSV, TXT, JSON, Sparkplug)

- with all of the data formats you can choose to send only the Data, or both the Data and the Diagnostic information
- the diagnostic information includes any error messages and shows details such as when the unit was restarting, any modem connection errors or sensor errors

#### **4.9.1 YDOC Native Data Format**

YDOC developed there YDOC Native Data Format to allow the units to capture both readings and all of the useful meta-data. When information is stored on the RTU’s SD card it is saved in this format.

The following will help you understand the contents of a data file downloaded in YDOC Native format:

- each row in the exported file can contain one of several types of information, each identified by the first character in the line
  - I Designates an Information line and carries information such as the site name, SIM ID etc
  - L Designates that this is a header row which contains information for each field which appears in the data file (field name, code / ID and engineering units)
  - S Designates a System message or error message
  - D Designates a data row
- the type indicator is followed by a time stamp then the values.

From the Configuration Menu, select **D - Modem Output** and then select your transfer type

- The RTU can send data to a server using a number of different methods:
  - TCP: used to send data to YDOC Insights or to a server running YDOC's TCP Server module
    - this mode is also used for remote connections using YDOC Terminal
    - you can set the RTU to use TCP with a "heartbeat" connection which allows it to regularly connect to the server and check to see if a remote connection is required
  - HTTP: used to send data to an HTTP or HTTPS server
  - FTP: used to send data to an FTP server
    - Sensori uses FTP transfer
  - MQTT : used to send data to an MQTT server
    - the payload can be sent in YDOC format or you can choose to use the "Sparkplug 4" format
  - Email: allows data to be sent as an email attachment (not available on Cat M1 units)
  - SMS: SMS data transfer is not available with Cat M1 / NB1 RTUs
- You can set a unit up for multiple transfer methods, and each can occur at a different rate
  - you may for instance send via FTP every 15 minutes but then add TCP every 4 hours to allow a remote connection
  - HTTP and TCP are mutually exclusive, so if you select one you can't use the other

- refer to your presentation software vendor for details on the transfer settings.

Note: if you are using the WiFi Option Board, menu option D - Modem Output will be inactive and you will need to select **E – WiFi Output** in order to select the transfer method and server.

## 4.9.2 Set the connection interval

For each connection method, the settings are much the same and you should be able to adapt the TCP settings to suit your FTP and MQTT servers.

You can use YDOC's on line Power Consumption calculator to determine whether a unit will get sufficient charge at a location to support the chosen sensors, log rate and transfer rate:

<https://www.ydoc.biz/datalogger-power-consumption.html>

From the TCP Menu select **2 Send Interval**

- You then have two options: Normal Mode and Alarm Mode
- Normal Mode is the rate during normal communications
- Alarm Mode allows you to send at a higher rate when an alarm has been triggered
  - Using the example of a stream monitoring station, you may wish to send data every 12 hours in Normal Mode but to send it every 15 minutes after an alarm
- Select the parameter (Normal or Alarm), then select the time base (Hours or Minutes), then from the list, choose the appropriate time period.

The normal interval must be greater than the alarm interval and must be greater or equal to the normal data log interval

## 4.9.3 Set the Send Delay

The Send Delay setting allows you to set a time delay to wait before commencing the data transmission. If you have a large number of RTUs sending data to the same server, you can stagger them so that they don't all hit the server at the same time. This is only needed if your server is slow or you have a very high number of devices. You should also keep the delay

less than 1 minute as the RTU will spend more time awake and hence use more power.

To set the delay:

- after selecting the Modem Mode in the Config menu, select option 3 – Send Delay
- then enter the time in seconds to wait before commencing the send.

#### 4.9.3.1 How the RTUs manage Sensor Read and Data Sending

The YDOC RTUs prioritise the sensor reads ahead of data sending. So if you have a Log rate of 15 minutes and an FTP send rate of 15 minutes and the FTP send is set to a delay of 0 sec, the FTP send will be delayed until after the read has completed

If you have more than one output type sent, they can both be set to the same delay time and the RTU will manage the sending of one then the other.

If you set a sensor warm-up time, the power will be turned on ahead of time, so the warm up period ends at the nominated time.

00:14:58    00:15:00

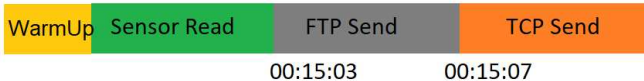

Example showing read/log on 15 min Interval with FTP and TCP send rate at 15 min with 0 sec delay

- If the warm up is 2 sec, power is applied 2 sec before the read
- FTP Send is initiated after sensor read is finished
- TCP send is initiated after FTP send is finished
- RTU goes back to sleep after TCP send completes

#### 4.9.4 Sending via TCP

TCP mode is used if you are sending data to the legacy YDOC Insights program or to a server running YDOC's Java based TCP Server module.

To set the TCP Server Address, select **4**

- If you are using the YDOC server, set the address to your-data-our-care.com

- If you are using TOIP's server set the address to `toip-server.net.au` or `120.150.31.37`
- if you are using your own copy of YDOC Insights or the YDOC TCP server, enter the IP Address allocated to it.

To set the Server Port, select	<b>5</b>
➤ Check that the port is set to	37
To set the TCP User Name, select	<b>6</b>
➤ Enter the User Name	e.g. <code>toip</code>
To set the TCP Password, select	<b>7</b>
➤ Enter the Password	e.g. <code>p10t</code>

#### **4.9.4.1 Complete a TCP Communications Test**

After checking that all of the parameters are correct, you can perform a test to ensure that the RTU can connect to the server and log in.

- To perform the TCP Test, select **T**
- The RTU will turn on the modem, connect to the GSM network, register on the data network, then attempt to log in to the server.

If the test fails, make sure that you have all of the TCP details correct. You should also check that you can still perform the Network and APN tests successfully.

After the test runs, you should check with the computer running YDOC Insights to which the data is being sent:

- The RTU sends a dummy file to the server
- The file will be stored in the folder  
C:\YDOC\YDOC Insights\archive\ydocdatacollector
- In this folder you will see a ZIP file for each RTU, with the files being named `DOC_YDOC_<serial_no>_<transfer No>.zip`
- The date and time stamp on the file should match the time of the test transmission
- You can open the file to check that it was received without corruption: it should contain a number of lines, each showing punctuation characters, 0 to 9, a to z and A to Z.

## **4.10 Sending Data via FTP**

In addition to, or instead of, transferring readings to YDOC Insights, you can set up an automatic transfer of the data to an FTP, FTPS or SFTP

server. This is the method used to send data to Sensori. The data file can be sent in YDOC native format or as a CSV file. Where possible use YDOC Native format as it includes all of the diagnostic information.

To add an FTP export:

- Connect to the logger and activate the menu
- Go to the Configuration menu
- Select Configuration Setup           3
- Select Modem Output                 D
- Select                                     4    FTP Output
- In the FTP Settings menu
  - Set the Name to the characters you wish to be added as a prefix to the file name (keep this short to reduce file size)
  - Set the interval to the required frequency e.g. hourly
  - Send delay: normally 0. If you want the send time to be offset from 00:00, set the delay. Note that the delay here is in seconds and the highest available value is 1000 (16 min and 40 seconds)
  - Set the remaining settings to match your FTP server
  - Perform an FTP Test (Option T) to confirm that the RTU can connect to the server, log in and transfer a file. You should then be able to log in to the FTP server and locate the test file.

The settings for transfer to Sensori are as follows:

Server URL	ftp.sensori.cloud
User	toipM844
Password	GHWGPOzF
FTP Mode	Passive
FTP Port	21
Security	Basic
FTP Directory	/
Output Type	Log Data
Data format	Native (txt)

File Name	Leave at the default
Verification	Set to YES
Max Payload	Set to 50 kB

Sending to Eagle IO:

- if you are sending to Eagle IO, enter the credentials given to you by them
- make sure Validation is set to NO: Eagle IO uses a custom FTP process which does not stay on long enough for the file verification step to complete.

To review the files that have been sent to the server, open an FTP Client such as FileZilla and create a session using the credentials shown above. Browse the "done" folder and there you will see a sub directory for each day, inside of which will be all the files transferred on that date.

## **4.11 Sending Data Via MQTT**

MQTT (Message Queuing Telemetry Transport) is a protocol which was designed in the early 2000's but was not widely adopted until the advent of the "Internet of Things " (IoT). It is a simple, rugged protocol designed around getting messages from one system to another. The addition of MQTT support to the YDOC RTUs means that readings can be sent to many of the new IoT server platforms. Within MQTT there are two types of device functions: Publishers, wherein devices make data available; and Subscribers, wherein devices subscribe to a feed of data from a Publisher. It is a two way system so devices can send sensor data and receive control commands.

When sending data from an RTU, the RTU becomes the publisher and the server the subscriber.

To set up a connection to an MQTT server:

- from the Logger Menu select **3** Configuration Setup
- from the Config menu select **E** Email Output
- from the TCP Menu select **R** to disable TCP
- now go back to the Config menu and select **3 MQTT Output**

- at option 2 set the Send interval to the required time (e.g. 15 min)
- at option 3 you can enter a delay to prevent all the devices hitting the server at the same time
- at option 4 enter the IP Address of URL for the MQTT server
- at option 5 enter the Port on which the MQTT allocated to the MQTT server
- at option 6 select the security you wish to use: 0 = Basic (port 1883) 1 = SSL (encrypted and on port 8883 normally)
- at option 7 & 8 enter the allocated User Name and Password for the account used to access the server
- option 9 is the Topic which will be used to identify this data stream on the MQTT server. Enter the name which you have agreed to use (e.g. YDOC/<serial\_no>)
- at option A select whether you want to use Sub-Topics or not
- at option B set the Client ID you wish to use for the MQTT sessions
- at option C leave this on No
- at option D select the Output Type of Log Data
- at option E select the Data Format (usually JSON\_)
- at option F set the size for the largest packet of data to send (can be left on the default)
- at option G set the Data Filter to Data & Diagnostics

You should test the MQTT connection to ensure it is working:

- from the MQTT menu select **T** MQTT Test
- the RTU will attempt to connect to the MQTT server using the topic and credentials supplied
  - if the test fails double check that the MQTT server is running and that the credentials and port are correct.

If you have access to the MQTT server you can watch for traffic from the RTU:

- using Mosquitto
  - if the server is running Mosquitto, you can use `mosquitto_sub` to subscribe to the topic
  - if the server is not running a large number of topics, you can use a wild card subscribe:  
e.g. **`mosquitto_sub -v -t '#'`**

- it is better to subscribe to just the “topic” which matches your YDOC
- e.g. **mosquitto\_sub -v -t /YDOC/<ydoc serial no>**
- when the unit sends the test message you should see:  
**YDOC/5000568/data/jsn (null)**

## 4.12 Sending Data via HTTP

The YDOCs support transfer of the data to a HTTP / HTTPS server. The data file can be sent in YDOC native format or as a CSV file. Where possible use YDOC Native format as it includes all of the diagnostic information.

To add an HTTP export:

- Connect to the logger and activate the menu
- Go to the Configuration menu
- Select **3** Configuration Setup
- Select **D** Modem Output
- Select **2** HTTP Output
- In the HTTP Settings menu
  - Set the Name to the characters you wish to be added as a prefix to the file name (keep this short to reduce file size)
  - Set the interval to the required frequency e.g. hourly
  - If you want the send time to be offset from 00:00, set the delay. Note that the delay here is in seconds and the highest available value is 1000 (16 min and 40 seconds)
  - Set the Server, port etc as shown below

The settings for transfer to Sensori are as follows:

Server	agent.sensori.cloud
Path	api/d/h/u/m844/tYhp/M3v
Port	80
Security	HTTPS
User	(blank)
Password	(Blank)
Output type	Log data

Data Format          Json

Note:

- the extended path includes an embedded user name ( tYhp) and password (M3v) so the User and Password entries are left blank
- make sure that you do not add the “http://” prefix to the URL – if you include it the export will fail
- make sure that there is no “/” character at the end of the Server URL or at the start of the Extended path.

Perform an HTTP Test (Option T) to confirm that the RTU can connect to the server, log in and transfer a file.

## **4.13    *Sending via Email***

You can Email the captured readings and camera images, to a nominated email address (Requires firmware version 4.9B1 or later). To set up for Email transfer:

- Go to the Configuration menu
- Select                    **3**    Configuration Setup
- Select                    **D**    Modem Output
- Select                    **6**    Email Output
- In the Email Settings menu
  - Name: Set the Name to the characters you wish to be added as a prefix to the file name (keep this short to reduce file size) e.g. Email
  - Send Interval: Set the interval to the required frequency e.g. hourly
  - Ised delay: f you want the send time to be offset from 00:00, set the delay. Note that the delay here is in seconds and the highest available value is 1000 (16 min and 40 seconds)
  - SMTP Server: Enter the SMTP server to be used for sending the email (e.g. [enviro@toip.au](mailto:enviro@toip.au))
  - SMTP Port: set the port to 465 (if your SMTP server uses a different port, change the setting to match)
  - Security: this must be set to          TLS Implicit

- User Name: set the User Name to the User account used to log in to the Email server (e.g. enviro)
- Password: enter the corresponding password
- Originator Address: this will normally be the same as the sender address e.g. [enviro@toip.net.au](mailto:enviro@toip.net.au)
- Destination Address: set the Destination address to the Email account to whom the readings will be sent
- Subject: set the subject to the RTU name
- Output Type: ensure the Output type is set to Log Data
- Data Container: select File Attachment so the data is sent as a file attachment
- File Name: normally you can use the default name but change it if your system requires a specific name
- Data Format: choose the format you want to use for the data
- Max Payload: this can be left on the default, or reduced if you want to keep messages below a set file size
- Data Filter: if you want to include the diagnostic messages, leave the Payload filter on Data & Diagnostics otherwise select Data

When you have finished the setup, run an EMail test (T) and confirm that the email is successfully sent. Then check on the receiving email account that it has arrived.

## **4.14 Sending via WiFi**

If you fit the RTU with a WiFi Expansion board, you can send data via the WiFi network, saving on SIM charges.

To Configure the WiFi output Select E – WiFi Output from the Configuration Setup Menu.

Set the credentials as shown in section 4.12 .

When you have completed the setup, run a HTTP or TCP Test

- the WiFi test has two stages: first it must connect to your WiFi Access Point and then when that is done it connects to the HTTP server
- if the test fails, double check the credentials and try again.

## 4.15 Starting the Logger

The RTU will start logging and sending values once it is put in to RUN mode:

- When the menu displays, check what level in the menu you are at
  - If any of the sub-menus display, press 0 to go back to the Configuration Menu
- At the Configuration Menu select Run by typing **0**
- The RTU will respond with a prompt to say it is running.

```
Init HTTPS
Running
ML-417ADS Logger Version 4.5 Build 2 (PT12-SDI-Unvented 110027418)
- for Configuration Menu: Press <Ctrl>A<Shift>M<Ctrl>D
- for Actual Values: Press <Ctrl>A<Shift>V<Ctrl>D
- for Processing Status: Press <Ctrl>A<Shift>S<Ctrl>D
- for Pausing Deployment: Press <Ctrl>A<Shift>P<Ctrl>D
Data log...System log...ALARM_SET;Tamper-case
Data log...System log...ALARM_SET;Tamper-cable
Sensor power on
Modem power on
```

- An RTU which has been configured will always return to RUN mode after a period of inactivity
- if the power is interrupted, an RTU will return to RUN mode once power is restored
- the RTU will also return to RUN mode after a period of inactivity.

## 5 Sensor Configuration

The ML417 can accept pulse, analogue and Serial (RS23, Rs485 and SDI-12) sensors. It can also log a range of internal parameters for diagnostic purposes.

The maximum number of parameters than can be logged is 63 and this number must include the internal and external sensors.

When planning your installation, consider the power requirements of the sensors and whether they need to be powered continually or will be switched on during the read. The YDOC unit has a DC-DC converter which can supply 12V at 100mA. If a higher current is required, you will have to use this output to drive a relay which in turn switches power to the sensors.

### 5.1 GSM Signal Strength Monitoring

The RTU allows you to log the GSM Signal strength for diagnostic purposes – especially when first setting up a new RTU:

- Go to the Configuration menu 3
- Select option 9 Network signal sensor
- Leave the log interval on the default value
- Select option 5 Network Signal dB
- Select option 1 and change the name to Signal Strength
- 1. you can also select Signal Bars instead of RSSI. Do not select both as this just wastes air time and increases data volume
- Save the changes.

Note that if you are in an area where signal strength is not likely to change, you may wish to disable the Signal Strength monitoring once the system is stable. This is because the modem must be powered up for additional time to record the signal strength. Turning this function off will thus help maximise battery life.

### 5.2 Adding Internal Sensors

The RTU can log a number of internal sensors to keep track of the unit's health. To add Internal sensors, go to the Configuration menu select **6 - Internal Sensors**

The list of available Internal Sensors and their status will display.

To enable a measurement, select the number next to it from the menu

- Interval: normally this is set to the same as the data logging interval, but you can change the rate
- Single use batteries: if you are using single use Lithium batteries you can keep a watch on battery life:
  - Battery Capacity: if you are using a Lithium battery, enter the battery capacity here, the RTU can monitor the battery charge status
  - Battery Replaced: when you fit a new Lithium battery, select this and choose 1 to record that a new battery has been fitted
- The list will update to show the parameters which are active and those which are not
- if you select a value by mistake, use the “R” option to delete it
- When finished, select 0 to exit and then Y to save the changes.

A useful selection of Internal Sensors is: Average voltage, Average current, Operating Cycle.

## **5.3 Adding Analogue Sensors**

Analogue sensors (Voltage and 4-20 mA) are only available on the “ADS” versions of the RTU, not with the “DS” units. There are two 4-20mA (Channels 1,2) and 2 voltage (Channels 3,4).

### **5.3.1 Voltage Sensors**

The voltage inputs on the RTUs are scaled for 0 to 10V. The channels have 12 bit resolution (4096 steps) so when used on 0 to 2.5V sensors, you will still achieve 10 bit resolution (1024 steps).

To add an Analogue voltage sensor on Port 3:

- From the Configuration Menu select **7 Analogue Sensors**
- Select **Port 3**
- When the Analogue Sensor menu displays, set the parameters for the sensor
  - Name Give the sensor an appropriate name e.g. Water Level
  - Power Switch: The Power switch should be enabled so the sensor is only turned on during the Read operation. Select 2,

then type 1 to enable the Power Switch, then enter the warm up time e.g. 2 sec

- Sample Interval Leave at the data log interval, unless you want this sensor to be read at a different rate
- Select Parameter Settings (5) and set the values to suit the sensor
  - Name Give the sensor a short name e.g. LEV
  - Code type a short code for the sensor. You should keep the code consistent for all sensors of this type e.g. WL (water level), AT (air temp) RH (Relative humidity) BP (barometric pressure), SR (solar radiation etc.)
  - Units Enter the units to be used for the measurement e.g. m (always try to use the standard SI measurement units)
  - Value factor: this allows you to enter a multiplier to scale the value :
  - Offset: an offset to be added to the reading.

### 5.3.1.1 Range Conversion

Analogue signals may be transformed using the Value Factor and Offset or with the Parameter Value at 0V and Parameter Value at 10V settings.

#### Value and Offset

The Value factor and offset are used together to provide simple calibrations in the form  $Y = a x + b$ , where  $a =$  Value factor and  $b =$  offset.

For instance with a 5m range sensor which is installed 20m below the surface. To express the level as a depth below the surface: Value factor = -1; Offset = 20. If the sensor reads 3m,  $y = -1 * 3 + 20 = 17$ m below the surface.

#### Parameter at xV

The Parameter values at 0V and Parameter Value at 10V (6 and 7) are used to specify the outputs to display at the 0V and 10V values.

For a relative humidity sensor which provides a 0 to 100% output over a range 0 to 2.5V:

- Value at 0V = 0%
- Value at 10V = Value at 2.5V X 4 = 400%

## 5.3.2 4-20mA Sensors

To add a 4 to 20mA sensor on Port 1:

- From the Configuration Menu select Analogue Sensors 7
- Select Port 1

- When the Analogue Sensor menu displays, set the parameters for the sensor
  - Name Give the sensor an appropriate name e.g. Water Level
  - Power Switch : The Power switch should be enabled so the sensor is only turned on during the Read operation. Select 2, then type 1 to enable the Power Switch, then enter the warm up time e.g. 2 sec
  - Sample Interval Leave at the data log interval
  - Port Mode Select 0 for sensors which are scaled for 4 to 20mA or 1 for sensors which are scaled for 0 to 20mA
- Select Parameter Settings (5) and set the values to suit the sensor
  - Name Give the sensor a short name e.g. LEV
  - Code type a short code for the sensor. You should keep the code consistent for all sensors of this type e.g. WL (water level), AT (air temp) RH (Relative humidity) BP (barometric pressure), SR (solar radiation etc.)
  - Units Enter the units to be used for the measurement e.g. m (always try to use the standard SI measurement units)
  - Value factor: this allows you to enter a multiplier to scale the value. For 4-20mA sensors, leave on 1
  - Offset: an offset to be added to the reading; for 4-20mA sensors, leave on 0
  - OK the changes and go back to the Analogue sensor menu
- Use the Parameter Value at 4mA and Parameter Value at 20mA to specify the readings at each end of the scale
  - E.g. for a water level sensor which reads over a 5m range, the value at 4mA would be 0m and the value at 20mA would be 5m
  - If you wanted to apply a depth to reference level e.g. for a sensor installed at a depth of 20m with a range of 5m, the Value at 4mA would be 20m and the Value at 20mA would be 15m.

## **5.4 Adding Pulse Inputs**

The RTUs allow you to capture pulse data in 3 different formats:

- Counter: a totaliser which captures the total rain or flow (and can be viewed as an equivalent to the dial on the front of a meter). This can be left incrementing continually or reset every day (running total daily rain)
- Quantity: captures the rain or flow in the log interval (the standard way of looking at rain)

- Rate: converts the pulse count in to a rate over time (i.e. converts a flow volume (e.g. 10 m<sup>3</sup>) to a flow rate e.g. 40 m<sup>3</sup>/hour
  - You can capture the actual, maximum and minimum rates.

By default, pulse sensors are added as a Counter; you can then enable the Quantity and/or Rate channels.

## 5.4.1 Rain Gauges

Rain Gauges are connected to any of the three Digital Input channels. To add a Rain Gauge on the first input:

- From the Configuration Menu, select **8 Digital Sensors**
- Select the Port – 1 for the first gauge **1**
- As this is a rain gauge, select 1 for a Digital Pulse input (if you were setting an entry alarm or other on-off channel, you would select 2)
- Now configure the settings to match the sensor
- Set the **Name** to                      Precipitation
- Leave the **Sample Interval**        at the Data Log Interval
- Leave the **Port Mode** on            Internal Pull-up
- Set the **Units per pulse**            to match the gauge
  - For a 0.2mm per tip rain gauge, the Units per pulse will be 0.2
- **Register Mode**                      Leave the on Pulse (low frequency)
  - You can change this if connecting to a high pulse rate flow meter
- **Register Value**                      this can be left on 0
- **Register Reset**
  - For a long term totaliser leave this to Off
  - If you want the totaliser to capture the daily rain (midnight), set it to On. The totaliser will then count up each day and reset at midnight
- Log each counter change        leave on Off
- Now select        **Counter**        9 and set the parameters for the Counter channel
  - Set the Name to            Daily Rain
  - Set the Code to            PRD
  - Set the Value factor to 0.2 (for 0.2mm per tip gauges)
  - Leave the Value factor and offset on 0
  - Set the Number of Decimals to 1
- Now select        **Quantity**        A and set the parameters for the normal pulse counter
  - Set the Name to            Rain
  - Set the Code to            PR

- Set the unit to           mm
- Set the Value factor to 0.2 (for 0.2mm per tip gauges)
- Leave the Value factor and offset on 0
- Set the number of decimals to 1
- Make sure item 7, Data log is set to    **On**
- If you want to capture the Rain Intensity, you can enable the Mean, Max and Min Rate at options B, C and D
  - Set the Name            Mean Intensity / Min Intensity / Max Intensity
  - Set the code            PRIAV / PRMN / PRIMX
  - Set the value factor to 1, the factor and offset to 0
  - Leave the decimals at 3.

Check all the settings and then save the changes.

## 5.4.2 Flow Meters

Flow Meters may be connected to any of the three Digital Input channels.

To add a flow meter on the first input:

- From the Configuration Menu, select **8 Digital Sensors**
- Select the                **1 Port – 1** for the first meter
- As this is a flow meter, select 1 for a Digital Pulse input (if you were setting an entry alarm or other on-off channel, you would select 2)
- Now configure the settings to match the sensor
- Set the **Name** to           Flow Meter
- Leave the **Sample Interval** at the Data Log Interval
- Leave the **Port Mode** on    Internal Pull-up
- Set the **Units per pulse** to match the rate given on the meter head e.g. 1 kl/pulse
- **Register Mode**            Leave the on Pulse (low frequency)
  - Change this to High if you are expecting more than 10 pulses per second
- **Register Value** – this can be left on 0, or if you want to make it read the same as the dial on a meter, type in the current meter reading
- **Register Reset**
  - For a long term totaliser leave this to Off
- Log each counter change – leave on Off
- Now select    **Counter**    9 and set the parameters for the Counter channel
  - Set the Name to        FL1 (or name of block on which meter installed)
  - Set the Code to        TOT

- Set the Value factor to the number of units per pulse
- Leave the Value factor and offset on 0
- Set the Number of Decimals to 1
- Now select **Quantity** A and set the parameters for the normal pulse counter which count the flow in each logging interval
  - Set the Name to Flow
  - Set the Code to FM
  - Set the unit to the units on the meter head e.g. kl
  - Set the Value factor to the number of units per pulse e.g. 1
  - Leave the Value factor and offset on 0
  - Set the number of decimals to 1
  - Make sure item 7, Data log is set to **On**
- If you want to capture the Flow Rates, you can enable the Mean, Max and Min Rate at options B, C and D
  - Set the Name Mean Flow / Min Flow / Max Flow
  - Set the code FLAV / FLMN / FLMX
  - Set the value factor to the number of flow units per pulse, the factor and offset to 0
  - Leave the decimals at 3.

Check all the settings and then save the changes.

### 5.4.3 Pulse Output Wind Speed Sensors

Pulse output wind speed sensors (anemometers) have the advantage that they are easy to read and do not require external power.

Pulse wind sensors may be connected to any of the three Digital Input channels. To add an anemometer on the first input:

- From the Configuration Menu, select **8 Digital Sensors**
- Select the **1 Port – 1** for the sensor
- Select 1 for a Digital Pulse input
- Now configure the settings to match the sensor
- Set the **Name** to Wind Speed
- Set the **Sample Interval** to 1 sec
- Leave the **Port Mode** on Internal Pull-up
- Set the **Units per pulse** to match the sensor
  - for Davis D6410 0.001032
- **Register Mode** leave the on Pulse (low frequency)
- You can change this if connecting to a high pulse rate flow meter
- **Register Value** leave this on 0

- **Register Reset**      leave this OFF
- **Log each counter change** – leave on OFF
- **Counter**              leave on NOT USED
- **Quantity**             leave on NOT USED
- **Mean Rate**            select and configure as follows
  - Name                  Wind Speed Avg
  - Code                  WSAVG
  - Unit                   set to match sensor e.g. km/h
  - Value factor        1    (or to convert to m/s 0.277778)
  - Value offset        0
  - Decimals            3

Check all the settings and then save the changes.

## 5.5 Adding SDI-12 Sensors

SDI-12 sensors are added in the Serial Port section of the Configuration menu.

From the Configuration Menu, select **A Serial port**  
Then for the Serial Port selection choose **3 SDI-12**  
The SDI12 Sensor menu will display.

To give the sensor a name choose **1** for a name

- Enter the name you want to use for the sensor e.g. Otto SMP

You must then set the sensor address

- From the menu select **2 Port Settings**
- From the Port Settings menu, select **4 Address**
- When prompted choose the address to use for the sensor e.g. 0

You can now set the power control parameters

From the menu select **3 Sensor Power Switch**

Select 1 to enable power switching: the sensor power will then only turn on when it is time to read the sensors

You will then be prompted for a Warm Up time in seconds before the read will be performed. If you are not sure whether one is needed, allow 2 seconds

>Sensor power switch usage (0 = Disabled, 1 = Enabled): 1

Warm up time (resolution 0.25 sec): 2

Set the Sampling Interval

- You can leave the SDI-12 read rate at the same figure as the Sampling Interval or can set it to a higher value to allow averaging
- If you have set the Sampling Interval to 15 minutes, the options available to you will be 1, 3, 5 and 15. If you select 3 for instance, the sensor will be read every 3 minutes and the 5 readings averaged every 15 minutes
- If you are using Event based logging (with a different rate after an alarm event) you can enter the rate to use after the alarm condition here under option 3.

Set the Measurement Command

- From the menu select **5** Measurement Command
- You will then be prompted for the Command Type – M or C – and the Measurement Number ( 0 to 9)
  - Select the command and measurement number to match your sensor

You must now add the individual measurements as parameters

From the Menu select **8** Parameter 1

Select 1 and give the sensor a name e.g. SM 010cm

Select 2 and set the Code for the measurement. Use the same code for a given type of measurement

- soil moisture SM<depth> e.g. SM010
- soil temperature ST<depth> e.g. ST010
- soil conductivity EC<depth> e.g. EC010
- air temperature AT
- relative humidity RH
- wind speed use WS
- wind direction WD
- leaf wetness LW
- solar radiation SR
- water level WL

Select 3 and enter the units e.g. %

If you want to apply a multiplier and offset, they can be added under options 4 and 5

- New value = (X x Value Factor) + Offset
- Value Factor multiplier with default of 0
- Value Offset Offset to be added to value, default = 0

After adding the sensor, select the **T** or Test option from the menu to test the sensor

- this will enable the SDI-12 bus power and send the measurement command out over the bus
- if the sensor is connected, it will return readings which will be displayed on screen
- alternatively you can use the real time value display mode and the "COM Port Terminal" function

## 6 Calculated Channels Formulas and Aggregates

### 6.1 *Creating Formulas and Averaging (Max, Min, Avg, Sum)*

The RTUs allow you to generate new Calculated channels based on the values of other sensors. This enables alarms to be configured on the calculated rather than the raw sensor value. You can also create Aggregated channels which calculate the average of sum of a tag value over time (e.g. for generating average wind).

If you are going to use long calculation formulae or multiple formulae, it pays to shorten the CODE for your tag to a single character i.e. instead of WSAVG use W.

#### 6.1.1 Adding a Calculated / Derived Channel

First perform the device setup and add the standard sensor as per section 5.5 . Then write down the formula you want to use to convert this raw value into a calculated channel.

Go back to the SDI-12 sensor setup and make a note of the **CODE** you have given to the sensor in the config e.g. a soil moisture sensor named SM010cm has been set a code of SM010; the Soil temperature sensor, ST010cm has been set a code of SM010 etc.

- When using sensors in the equation you prefix the code with a colon e.g. :SM010 or :SM010.

To create a calculated sensor:

- From the main menu select **3** Configuration Setup
- From the Config menu select **C** Derived Channels
- from Derived Channels select **2** Calculations
- To add the first calculated channel **1** Channel 1
- Now select the first Parameter **1**
- Enter the new name for the channel e.g. SM Cal 010cm
- Give the new parameter a short code e.g. SMC010
- Select the Engineering Unit for the sensor e.g. mm
- Accept these settings
- Now select the Formula option **2**

The Formula Editor will display. The editor shows you the range of available functions.

Parameters Must be prefixed with a colon (":")  
e.g. :SM010

Supported operators: + - \* /

Supported parentheses: ()

Functions with one argument:

- abs(x) returns the absolute value of x
- age(x) returns the number of seconds since the last reading
- sqrt(x) returns the square root of x
- ln(x) returns the natural logarithm of x
- exp(x) calculates the exponent of e to x
- sin(radians) returns the sinus of radians
- cos(radians) returns the cosine of radians
- tan(radians) returns the tangent of radians
- asin(x) returns the arc sinus of x in radians
- acos(x) returns the arc cosine of x in radians
- atan(x) returns the arc tangent of x in radians
- torad(degrees) converts degrees to radians
- todeg(radians) converts radians to degrees
- floor(x) returns the largest integer not greater than x
- ceil(x) returns the smallest integer not less than x
- round(x) rounds to the nearest integer

Functions with multiple arguments:

- atan2(x;y) return the arc tangent of x/y
- daytime(x;y)

mod(x;y) return the remainder of x/y  
pow(x;y) returns x to the power of y  
clip(x;min;max) returns x clipped between min & max

Comparisons with 2 arguments:

eq(x;y) returns x if x=y else y  
lt(x;y) returns x if x<y else y  
le(x;y) returns x if x<=y else y  
gt(x;y) returns x if x>y else y  
ge(x;y) returns x if x>=y else y

Comparisons with 4 arguments:

eq(x;y;p;q) if x=y returns p else returns q  
lt(x;y;p;q) if x<y returns p else returns q  
le(x;y;p;q) if x<=y returns p else returns q  
gt(x;y;p;q) if x>y returns p else returns q  
ge(x;y;p;q) if x>=y returns p else returns q

Other Functions:

:<param>.AGE returns the time since the last reading  
the AGE value is reset each time a reading is  
made  
pi returns the value of pi (3.1415926)  
time returns the number of seconds since midnight  
in the time zone set for the RTU

## 6.1.2 Example Calculations

The following section shows some sample calculations which may be used in the YDOC units. Unless otherwise shown, the formulae use the parameter codes shown below:

:AT Air Temperature  
:RH Relative Humidity  
:WS Wind Speed Avg  
:LEV Water Level  
:SM Soil Moisture (single sensor)

As the number of characters available to hold a formula is limited, if you have long formulae, cut the CODE back to a single character  
e.g. air temp = a.

### 6.1.2.1 Checking the time since the last reading (AGE)

The AGE function tracks the time taken since a sensor tag was last read.

To test if the last value of the sensor LEV was over an hour ago use the AGE function in combination with a greater than test

```
gt(:LEV.AGE;3600;1;0)
  returns 0    if age < 1 hour
  returns 1    if age > 1 hour
```

### 6.1.2.2 Soil Moisture Calibration with polynomial equation

You can create complex formulae to apply calibrations for specific sensors.

The calibration for an MP03 takes the form:  $ax+bx^2+cx+d$

For a 50/50 mineral-organic soil : a = 0.0007 b = -0.01226 c = 1.53233 d = -27.231

To enter this in the formula editor (assuming that the raw soil moisture reading is M10):

```
0.00007*pow(:M10;3) - 0.01226*pow(:M10;2) + 1.53233*: M10
- 27.231
```

- After entering the formula look at the line below the formula to see if it shows an error message:
  - If the result shows 0 or a number (assuming the sensors has readings) then the formula has no errors
  - If the line shows “Error at position : x” , review the formula and correct the error.

You can use this function to calculate the Soil Moisture Sum (Refer Section 5.5 for info on setting up SDI-12 soil moisture sensors) in the RTU rather than in the software:

- Assuming you have a 5 sensor soil moisture probe with sensors at 10, 20, 30, 50 and 70cm
- Review the setup of the sensors and record the “Code” you have allocated to each: in this case assume that they are SM010, SM020, SM030, SM050 and SM070
- The formula would become:
 

```
:SM010 + :SM020 + :SM030 + :SM050 + :SM070
```
- After entering the formula look at the line below the formula to see if it shows an error message:

- If the result shows 0 or a number (assuming the sensors has readings) then the formula has no errors
- If the line shows “Error at position : x” , review the formula and correct the error

### 6.1.2.3 Wet Bulb Temperature

The Wet Bulb Temperature (WBT) can be calculated from the current air temperature and relative humidity.

Inputs:

Air Temperature :AT  
Relative Humidity :RH

$$(-5.806+0.672*AT-0.006*AT*AT+(0.061+0.004*AT+0.000099*AT*AT)*RH+(-0.000033-0.000005*AT-0.0000001*AT*AT)*RH*RH)$$

### 6.1.2.4 Delta-T

The Delta T (DT) which is the difference between the Wet Bulb and Dry Bulb Temperature, can be calculated from the current air temperature and relative humidity.

Inputs:

Air Temperature :AT  
Relative Humidity :RH

$$AT-(-5.806+0.672*AT-0.006*AT*AT+(0.061+0.004*AT+0.000099*AT*AT)*RH+(-0.000033-0.000005*AT-0.0000001*AT*AT)*RH*RH)$$

### 6.1.2.5 Fire Danger Index (2m)

Inputs:

Air Temperature :AT  
Relative Humidity :RH  
Wind Speed (2m) :WS

$$POW(10;(0.009254+(0.01201*AT)+(0.2789*(SQRT(:WS)))-(0.09577*SQRT(:RH))))$$

### 6.1.2.6 Dew Point Temperature

The Dew Point Temperature (DPT) is an estimate of the temperature at which moisture will condense from the air: if the temperature is above zero dew will form and if it is below 0, frost will form.

Inputs:

Air Temperature :AT  
Relative Humidity :RH

$$:AT - (14.55 + 0.114 * AT) * (1 - (0.01 * :RH)) - ((2.5 + 0.007 * :AT) * \text{POW}(((1 - 0.01 * :RH)),3) - (15.9 + 0.117 * :AT) * \text{POW}(1 - (0.01 * :RH)),14)$$

### 6.1.2.7 Vapour Pressure Deficit

The Vapour Pressure Deficit is an estimate of the difference between the amount of moisture in the air at present compared to the maximum that could be held when it is saturated. Transpiration will increase as the VPD rises.

This calculation estimates the Vapour Pressure Deficit in kPa

Inputs:

Air Temperature :AT  
Relative Humidity :RH

$$(1 - 0.01 * :RH) * 0.61078 * \text{EXP}((17.2694 * :AT) / (:AT + 238.3))$$

### 6.1.2.8 Barometric Pressure Compensation

Barometric Pressure Sensors measure air pressure at the altitude at which they are installed. This can be converted to sea level air pressure (QNH, which is the standard definition of air pressure) by applying an offset for temperature and height above sea level.

Air Temperature :AT  
Barometric Pressure :BP  
Height above sea level h (substitute with actual height in m)

Simple calculation:

- the simple method ignores temperature and only considers altitude change

- set the Offset in the Baro Pressure Parameter setup to a value equal to  $-(h * 0.12)$ 
  - e.g. for a station at 200m above sea level, offset =  $-200 * 0.12 = -24$  hPa

### 6.1.2.9 Conditional Calculations

You can use conditional statements to set up an alarm that will only trigger if for example flow has been detected or a pump is running.

Assume an open water reservoir for irrigation purpose, with a requirement for a warning when the water falls below a certain level or when the water level reaches the edge of the reservoir. But alarm sending can be disabled if water levels fall or rise when there is no usage or refill.

To avoid unnecessary level alarms you can define a calculated channel with the following equation:

`ALARMLEVEL = gt(:FLOWIN; 0; :LEVEL; gt(:FLOWOUT; 0; :LEVEL; LEVELOK))`

Where:

- `gt(a; b; c; d)` is a function that returns the value **c** when **a>b** otherwise it returns **d**.
- `:FLOWIN` is the monitored supply flow or a digital switch indicating an open valve/floodgate
- `:FLOWOUT` is the monitored demand flow or a digital switch indicating an open valve/floodgate
- `:LEVEL` is the monitored level in the pond
- `LEVELOK` should be substituted by a level value that does not ring any bells, a pond level somewhere between low and high limit.
- `ALARMLEVEL` is the defined calculated channel, which will be set to the same value as `:LEVEL` when there is a supply (`:FLOWIN > 0`) or demand (`:FLOWOUT > 0`) flow, else it will return a level that does not ring any bells (`LEVELOK` value).

Instead of setting low/high limits to `:LEVEL` you should set the warning limits to the `ALARMLEVEL` channel.

For safety reasons you could still set low-low/high-high limits to `:LEVEL`.

### 6.1.2.10 Valiantzas ETo

This calculation runs at the log interval. Sum the individual values to yield the daily ETo.

Set the CODE for the input parameters to:

t Air Temperature  
 h Relative Humidity  
 w Wind speed (2m)  
 s Solar Radiation  
 z Latitude of site in radians =  $2 * \text{Pi} * (\text{lat}/360) = 6.2857 * \text{lat}/360$   
 e.g latitude = -34.78, L =  $34.78/360 * 2 * \text{Pi} = (34.78/360) * 6.2857$   
 = 0.607  
 A in expression =  $(L * 0.01746)^{0.15}$   
 A =  $(L * 0.01746)^{0.15}$   
 A =  $(0.607 * 0.1746)^{0.15} = 0.928$

Generic Formula:

$$0.0393 * (u * 0.0864) * \text{POW}(:t+9.5;0.5) - (A * 0.19 * \text{POW}(:s;0.6)) + (0.048 * (:t+20) * (1 - :h/100) * \text{POW}(:u/3.6;0.7))$$

Set the Formula to:

$$0.0393 * (u * 0.0864) * \text{POW}(:t+9.5;0.5) - 0.1786 * \text{POW}(:s;0.6) + (0.048 * (:t+20) * (1 - :h/100) * \text{POW}(:u/3.6;0.7))$$

### 6.1.2.11 Penman Aerodynamic ETo

The Penman Aerodynamic ETo model requires air temperature, relative humidity and wind speed. It may be run on stations which do not have a solar radiation sensor.

This calculation runs at the log interval rather than once per day. Sum the individual values to yield the daily ETo.

Set the CODE for the input parameters to:

t Air Temperature  
 h Relative Humidity  
 w Wind speed (2m)

Set the Formula to:

$$(0.35 + 0.084 * :w) * (1 - 0.01 * :h) * 0.6108 * \text{EXP}(17.27 * t / (:t + 237.7))$$

## 6.2 Using Aggregate Channels

Aggregation allows you to calculate time based averages or totals. For example, with pulse wind speed sensors and with analogue sensors it enables you to calculate the Average, Maximum and Minimum over the full sampling period. It can also be used to create a Vector Wind Average or to total the evapo-transpiration or rainfall for the day.

The RTU can accommodate up to 8 Aggregate channels, each which can handle 600 values. The sampling rate and log rate must be chosen to fit within this 600 value range e.g 10 minute log period allows 1 sec sample rate; for 15 minute log rate use 2 second sampling rate.

When creating an Aggregate Channel:

- set the Log Rate for the channel at the rate you want to read it e.g. 1 min
- on this channel set **Data Log to Off** (unless you want to log all the individual readings as well)
- set the Log Rate on the Aggregate channel to the rate at which you want to log (e.g. 15 min).

To add an Aggregated Channel:

- First set the wind speed sensor up as a Digital Input (Refer section 5.4.3 ) , Analogue Input or SDI-12 input
- give the sensor a short form name e.g. S instead of WS for Wind Speed
- normally you will not want to log the individual samples, so set Data Log to OFF
- Set the Log Rate to the interval at which you want the sensor scanned e.g. 1 min
- Save the sensor setup
- From the Config Menu select **C** Derived Channels
- When the Derived Channels option displays, select **1** Aggregations
- select the first Aggregated Channel
- select 1 and give the aggregated channel a name e.g. WS Aggregate
- select 2 and set the appropriate Aggregation Period e.g. 10 min> Note that this can be the same as the Log Period or shorter (e.g. if log period = 15 min and Aggregation period = 5 min you will get a rolling 5 min average)
- leave option 3 (Vector Aggregation) off
- select option 4 and set the Name to Wind Speed Avg

- select option 5 and set the Name to Wind Speed Min
- select option 6 and set the Name to Wind Speed Max
- the Wind Gust may also be selected at option 7: this is the highest 3 sample average over the aggregation period

If adding a Wind Direction Sensor:

- set the Name to Wind Direction
- set Vector Aggregation to ON
- enable Average Direction and Deviation

## 6.2.1 Aggregates and Totalisers

If you are using a Flow meter which outputs a Totaliser value but not the flow for the period, you can derive the flow using an Aggregate Channel. The RTU can then perform the aggregation by taking the difference between the Totaliser value at the start of the period and the end of the period. But to ensure you get the correct value, the start value must be the value at the end of the last log period: if you are logging every hour and aggregating every 5 minutes, then the Aggregation Period needs to be  $3600 + 300 = 3900$  sec

- first off, note the CODE used by the sensor for the Totaliser e.g. TOT
- from the menu create a new Aggregate channel: Config Menu, then C Derived Channels and then 1 for Aggregations
- select the first Aggregate Channel (e.g. 1)
- when prompted, enter the name for the tag which is providing the input data e.g. TOT
- the Aggregation channel properties will then display
  - leave the Type set to Scalar
  - set the Aggregation Period to a suitable interval e.g. 300 sec
  - if you are logging every hour, the Log Period is 3600 seconds
  - from the list of options, select A - Rate of Change
  - set the parameters for the new tag e.g Name = Flow, Code = FLOW, units = kL
  - save the channel
- allow the unit to log flow and confirm after a couple of log intervals that the value is calculating properly.

### 6.3 Testing SDI-12 Sensors

The RTU provides a facility for configuring and testing SDI-12 sensors. This is referred to as Com Port Terminal i.e. commands typed to the USB port are directed to the SDI-12 port.

To activate COM Port Terminal:

- From the menu select **5 Maintenance**
- Then select **2 Com Port Terminal**
- Then select **1 Serial Port**

Note: if your configuration only has SDI-12 sensors, the unit will skip this step

- The RTU will then display a message saying Comport Terminal mode is active
  - LED 3 will turn on to indicate that the USB port is active
  - The PS ON LED will turn on indicating that the switched sensor power is on
  - If you do not type any commands for 30 seconds the function will time-out
- You can now type commands which you want sent to the sensor
  - Note that the commands are not echoed on the screen
  - Make sure the commands are sent in Upper Case
  - Each command must terminate with an exclamation mark ("!")

e.g. Type                   0!  
       RTU Responds with  013TEKBOX\_LCSMP\_2.30\_00088

e.g. Type                   0C1!  
       RTU responds with  000102

      Type                   0D0!  
       RTU responds with  0+5.23+16.26
- You can issue all of the standard SDI-12 commands or any Extended commands accepted by the sensor
- When finished, type CTRL Z or allow the function to time out.

If you do not see a response when you type SDI-12 commands into the terminal window:

- measure the battery voltage and make sure it is above 3.9V. If the battery voltage is lower than this, try a set of charged fresh batteries or with another Cover (e.g. a DC-AA cover connected to a plugpack)

- make sure that the modem light is not on: when the modem is powered up the combined current draw for the modem and the DC-DC converter which powers the SDI-12 sensors is too high. Wait until the modem light goes off and then try again
- if there is not already sensor connected to the unit, connect one and set the configuration to suit. Set the Log rate to 5 minutes and then, after setting the unit to RUN mode, watch to see that the sensors have been read

## **6.4 Powering High Current Drain Sensors**

The DC-DC Converter which generates the 12V supply for your sensors can only supply 200 mA.

### **6.4.1 SLA Power Board**

If you are using the SLA charge board, high current sensors can be connected to the 12V output on the board. The latest release of the SLA charge board includes a 2A switched output, which is available on the 7 pin header (previous versions used a 5 pin header) i.e. OUT Header Pin 7. To switch this output on and off, connect a wire from pin 1 of header X4 to Pin 6 of the OUT header. The output will then turn on whenever the switched power is on.

This output will turn off if the battery voltage falls below the safe level.

### **6.4.2 External Relay**

If you require a switched high power output on any of the other charge boards, add a Solid State relay, which is controlled by the switched power on X4 Pin 1 but which switches the 12V output from the SLA board.

The initial current on start-up for some sensors (inrush current) is high enough to trip the over-current protection on the switched 12V supply. But once this initial peak has passed, the RTU may be quite capable of powering the sensor. If an over-current condition occurs, the red LED on the switched 12V output will fail to turn on when the sensor is powered up (or will flash briefly). If this happens, try adding a 22 ohm, 1W resistor in series with the 12V supply. This will limit the maximum current to a value below the threshold at which the over-current protection trips.

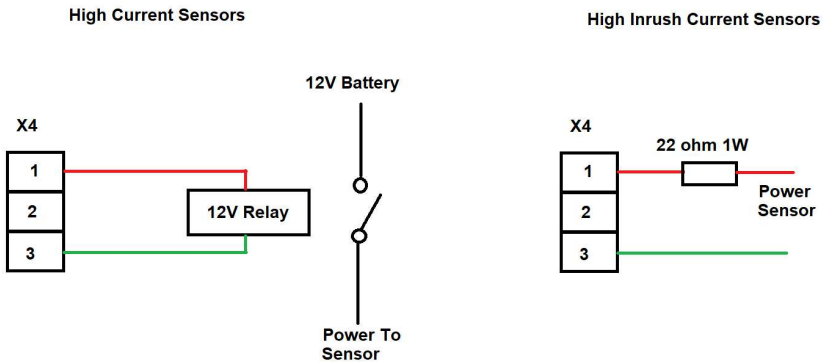

### 6.4.3 ML-OP-524 Expansion Board

The ML-OP-524 expansion board can also be used to generate a 12 or 24V supply for external sensors:

- install the OP board on the Expansion port of the YDOC
- set the voltage link on the OP board to give either 12 or 24V
  - no link = 5V
  - 12V link = 12V
  - 24V link = 24V
- set the mode link to “Internal” and the power will be turned on whenever the sensor power is on.

## 6.5 Setting up Alarms

The RTUs can be configured to send an SMS alarm or Email (not available with Cat M1 & NB1 devices) or to turn on the Alarm output, when the values of a parameter go beyond specified limits. These alarms are separate from the alarms which may be added within Sensori.

Alarms can be added based on the value of any physical or calculated channel. Although this section refers to setting up alarms on an analogue channel, the process is the same for other types of channels.

The RTUs define two levels of high and low alarm:

- Low limit - generally used for a warning
- Low low limit - used for an alarm
- High limit - generally used for a warning
- High high limit - used for an alarm

You can enter a delay (number of samples) that a condition must stay above/below a threshold before the alarm is triggered and a hysteresis value (to prevent multiple alarms if a value is hovering around the alarm value).

## 6.5.1 Setting up an Alarm SMS

Note that SMS alarms are not available on the Cat M1 / NB 1 RTUs only on the 3G4G only units

### 6.5.1.1 To add an SMS alarm:

- Go to the RTU menu and select the Configuration Menu
- First you must enable SMS alerts. There are two levels of Alerts: System Alerts (which warn for events such as a delay in communication) and Data Alerts (which test the value of a sensor)
  - System alerts can be useful for diagnosing problems with communications and can be turned on for testing and then disabled again
  - Because all of these functions are available remotely, you can setup and change alarms without visiting the site
- To set up a Data Alert:
  - Select the option **4 Alarm SMS**
  - Select **2 Data Alarm**
  - Then select option **1** to enable the alarms
  - Select option **3 Cellphone First recipient** and enter the mobile phone number to which you want the alarm to be sent
  - Select option **4 Cellphone Second recipient** and enter the second mobile phone number to which you want the alarm to be sent
  - You can now perform an SMS test and send a test message to the selected phone. Note that the SMS Test will not work if you are remotely connected because the modem is already in use for the connection
- Now go back to the Configuration menu and select the channel to which you wish to add an alarm (this example assumes an analogue channel)
- Select the Parameter number for the channel to edit is settings
- Select option **9 Alarm SMS** and then select **1** to turn the alarm SMS on for this channel. The full parameter list will display, which includes all the alarm settings

- **Option C Low low limit** Enter the value at which you want the low alarm to occur
- **Option D Low limit** Enter the value at which you want a warning to occur: set the value to the minimum range if you don't want to use this warning
- **Option E High limit** Enter the value at which you want a warning to occur: set the value to the maximum range if you don't want to use this warning
- **Option F High high limit** Enter the value at which you want the high alarm to occur
- **Option G Alarm set delay** This is normally on 1 so the alarm will occur as soon as the event occurs. If you enter a value higher than 1, the condition will need to be met for that many successive samples in order for the alarm to be sent
- **Option H Alarm reset hysteresis** The hysteresis value can be adjusted to prevent un-necessary alarm repeats. For a High alarm at 70 and a hysteresis of 5, the value must drop down to 65 before another high alarm will be accepted.

The text below shows a Low (Lo) and Low-Low (LoLo) alarm from a water level sensor. The alarm shows the RTU mobile number, RTU name, Tag name, Alarm name and current value:

2016/01/21 06:38:20AM

From: +61437772480 YDOC\_148 5900148: waterlevel 2m Lo  
Alarm 32.962 cm

2016/01/21 07:18:16AM

From: +61437772480 YDOC\_148 5900148: waterlevel 2m LoLo  
Alarm 28.539 cm

## 6.5.2 Setting up an Alarm Email

Alarms can be notified by Email on the Cat M1 and 3/4G devices. To add an Email alarm to an RTU:

- Go to the RTU menu and select the Configuration Menu
- First you must enable Email Sending
  - from the **Config** menu select **Email Output E**
  - select **1** Name and change this to Email Alarm
  - leave the Send Interval **2** at 6 hour
  - leave the Send delay **3** set to Not Used
  - select **4** SMTP Server and enter the name of your Email Server

- check with your Email provider for the SMTP Port to use. If unsure, leave on the default value
- select **6** User Name and enter the User Name used to log in to the mail server
- select **7** Password and enter the password for login
- select **8** Originator address and enter the Email address from which the Emails will be sent
- select **9** Destination address and enter the email address for the recipient
- select **A** Subject and enter the Subject you wish the emails to carry e.g. YDOC RTU <nnnnnn> Alarms
- make sure that the Data Format at B is left on Native
- select **B** Data Filter and select Diagnostics
- select Option **0** and save the changes, then come back to the Email menu again
- select **T** Test to send a test message. Wait for the test to complete and check that the message is received by the intended target. If not, double check all the settings and try again
- Now go back to the **Configuration menu** and select the channel to which you wish to add an alarm (this example assumes an analogue channel)
- Select the Parameter number for the channel to edit its settings
- If you had previously enabled Alarm SMS sending **9** disable it now
- select option **A** Alarm Log and set it to ON
- select Option **B** The full parameter list will display, which includes all the alarm settings
  - Option **C** Low low limit Enter the value at which you want the low alarm to occur
  - Option **D** Low limit Enter the value at which you want a warning to occur: set the value to the minimum range if you don't want to use this warning
  - Option **E** High limit Enter the value at which you want a warning to occur: set the value to the maximum range if you don't want to use this warning
  - Option **F** High high limit Enter the value at which you want the high alarm to occur
  - Option **G** Alarm set delay This is normally on 1 so the alarm will occur as soon as the event occurs. If you enter a value higher than 1, the condition will need to be met for that many successive samples in order for the alarm to be sent

- **Option H** Alarm reset hysteresis The hysteresis value can be adjusted to prevent un-necessary alarm repeats. For a High alarm at 70 and a hysteresis of 5, the value must drop down to 65 before another high alarm will be accepted.

If your RTU can not send an Email, download and review the data file (in YDOC Native format). Look for any WDT (watchdog timer) entries relating to the Email sending

- YDOC uses the SMTP command stack built in to the Telit modems. Telit incorrectly used the HELO command to log in to SMTP servers rather than the expected EHLO command. Most Email servers are now configured to reject this
- Telit added an SMTPCFG command to the modem firmware which, in conjunction with Version 3B.05 and later includes a command to switch the modem so it uses the correct command
- contact TOIP to organise an upgrade to the firmware in the modem on your RTU (or a changeover PCB).

### 6.5.3 Using the Alarm Output

The YDOC RTU has an “Open Collector” output which can be used to drive external relays. The output can carry (sink) only 20mA of current – it can not supply a voltage, only switch an external voltage source to ground.

The switched output in on X4 Pin 2

The external supply can be taken from a separate power supply (nominally 12V). If your RTU is using the SLA charge board, it can come from the 12V OUT on the charge board.

When the alarm condition is active, the transistor shown in the image at right, turns on, allowingt current to flow from the V Supply, through the load to ground.

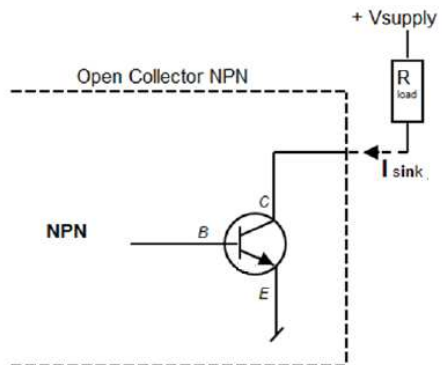

The load can be a small, low current mechanical relay or a solid state relay

- the latter will allow higher currents to be switched
- if you are using a mechanical relay, you must include a protection diode across the relay coil
  - the diode is wired in the reverse direction i.e. no current flows through it when the relay is on
  - when relay coils are turned on, a large electro-magnetic field builds up in the coil. The field breaks down when the relay is turned off, which results in a large current spike through the circuit driving the coil
  - when the diode is added, the coil's field discharges itself harmlessly through the diode.

The external relay should be wired as shown in the sketch below.

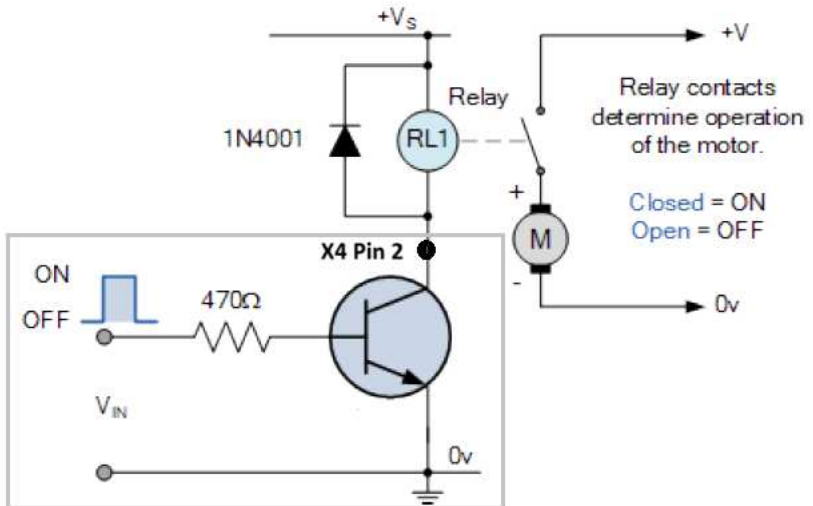

To activate the alarm:

- activate the configuration menu and select 3 Configuration Setup then 4 Alarm Settings
- select 4 Alarm Output port and select 2 Continuous state (the alarm will remain on while the condition is active)
- go to the sensor tag which you will be using to trigger the alarm
- display the Parameters for the sensor tag
- at option B Alarm log, select 1 to turn alarm logging on

- the parameter display will expand to show the High and Low limit settings
- if you want the alarm to be delayed (i.e. must be on for 2 readings) you can set the Alarm Set Delay at option H
- the Alarm Hysteresis controls how much the signal which caused the alarm must drop below the threshold before a new alarm can be recognised: if you have a rising alarm at 90% RH and have a 5% hysteresis, the RH must fall below 85% before a new alarm can be triggered
- if you want the RTU to shift to a higher read rate during alarm, set the Alarm Logging rate (and the Send rate).

## 7 Saving and Uploading Configurations

After you have configured an RTU you can save the configuration file on your PC. You can then reload it in to the RTU if the configuration is lost or use it to configure a replacement RTU if the RTU fails. In the same way you can also create files to match your most common RTU configurations and load them in to the logger rather than setting up each function manually.

### 7.1 Saving an RTU Configuration

Once you have finished configuring the RTU, make sure that you work back through the menu tree and save the changes. To save a configuration:

- At the main menu select **5 Maintenance**
- From the Maintenance Menu select **5 Configuration Download**
  - The RTU will show the Sending file dialogue
- when prompted, select the destination directory.

### 7.2 Loading a Configuration to an RTU

Connect to the RTU using the USB cable and open HyperTerminal or YDOC Terminal then:

- At the main menu select **5 Maintenance**
- From the Maintenance Menu select **6 Configuration Upload**
  - The RTU will show the Receiving file dialogue
- Click on **Transfer / Send File**, then browse to locate the file holding the configuration
- The file will be transferred to the logger
- when the transfer finishes you will be prompted as to whether you wish to overwrite the site name
  - if you are copying the config to a duplicate site, answer No
  - if you are replacing an existing RTU which has failed, answer Yes
- After the transfer completes, review the configuration and make any needed changes i.e. altering the Serial Number or Site Name.

## 8 Accessories and Expansion Boards

### 8.1 Setting Up a Camera

A Camera (Part Number YDOC-CAM-D1) may be connected to the ML417ADS unit. Refer to section 2 for details on ordering. If you want to send the images to your own server, set the transfer mode to FTP; if you want to view the images in YDOC Insights, use TCP Transfer mode.

The camera plugs in to the Accessory port via Connector (X5). Cameras are supplied with a 7 pin header pre-wired to the cable. You will need to remove the header in order to feed the cable through a cable gland on the logger



- If you have not already drilled the case, add an extra gland for the camera cable
- If the cable colours are different from the table below, make a note of the colours of the wires on each terminal then disconnect the header
- Feed the cable through the cable gland
- Re-terminate the camera cable using the colour codes identified above (Pin 1 is on the left).

Accessory Pin	Colour	Function
1	Red	Power
2	Black	Ground
3	-	-
4	Yellow	Tx
5	Green	Rx

The camera should be mounted to the pole on which the telemetry unit is installed using a suitable bracket. The camera mount can be adjusted through various angles and you can select from 3 different mounting positions on the camera to help keep it balanced at the angle on which it is installed.

Add the camera to the configuration:

- From the menu select **3 Configuration Setup**
- Select **B Accessory Port**

- From the list of options select **Camera**
- Makes sure that Independent Data log (5) is set to ON (so the camera can send images at a different rate to the other on board sensors)
- Set the Sample log interval under option 6 to the number of hours between pictures hours (or more often if needed)
- If you want to offset the time the images will be taken select
  - 7 Interval Shift and enter the offset to use
    - If this is not set the image will be taken at 00:00
    - Set the offset to the number of minutes after 00:00 at which you want the photo to be taken e.g. 360 for 6 am
- Select 9 Picture Size
  - A higher resolution yields better images but requires a higher data allowance on your SIM card
  - Monthly data requirement = horizontal resolution X vertical resolution X number of images per day X 31 X 1.05 (to allow for overheads)
- select B Picture Storage and select whether you want the images to be retained on the SD card or to be deleted after being sent
- Now test the connection by selecting option T Camera Test
  - The RTU will take a test image to confirm communications with the camera are OK
  - This image is not sent to the FTP server but via the USB cable to your PC

```
[T] Camera test    >> Not done
>
  Camera test
<15:39:26>
Shooting...
```

- After a few seconds you should be prompted to transfer the file to your PC

```
<05:56:48>
Select Y-Modem transfer from your terminal program menu,
to receive the picture file "ML-315_YDOC_152.jpg"
```

```
Press <Esc> to abort transfer
Sending...
```

- From your terminal program, select **Receive File** and set the protocol to **Y-Modem**
- When the download has completed, open the file and check that the image is OK.

### 8.1.1 Sending via FTP

Set the credentials on the FTP server you are going to be sending the images to. If you are using FileZilla

- Create a Group to which all accounts used for downloading will be a member of e.g. group = ydoc
- Create an account on the FTP server for the RTU
  - Give the account the same name as the “Name” in the FTP settings of the RTU e.g. ydoc\_<serial Number> for a logger with Serial Number 152, use a name of “ydoc\_152”
  - Make sure the account type is set to require a password and allocate a suitable password
- In the Shared Folders section of FileZilla, create a folder for the user e.g. ftp/ydoc/ydoc\_152
- Make this folder the user’s “Home” folder
  - Any files transferred by the RTU will be transferred to this folder
- Give the user Read, Write, Append and Delete permissions to the folder.

Now set up the FTP parameters in the RTU:

- From the Configuration Menu select **D TCP Output**
- Enter the details for the server to which you are sending the images.
  - Name ydoc\_<serial Number>
  - Send interval typically 1 per day but set to meet your requirements
  - Send delay An offset from 00:00 after which the image will be taken. Entered in minutes.  
TO shoot at 6:00 am offset =  $60 \times 6 = 360$
  - Password as per FTP account
  - Server toip-server.net.au (or URL of your own server)
  - Port 21 (or port for your server)
  - User Name ydoc\_<serial Number>
  - Password as per setup of FTP account
- After checking the settings, select 0 from the menu and when prompted, save the changes.

After completing the setup, perform an FTP test **T** to make sure you can connect to the server

- A small text file should have been transferred to the FTP server. The file contains 50 rows of alphanumeric characters
- If the test fails check with the administrator of the FTP server: the server log files should show the incoming login attempt and the reason for the transfer being disallowed.

## 8.1.2 Camera Troubleshooting

For diagnostic and troubleshooting purposes, you should connect to the RTU using YDOC Terminal.

### 8.1.2.1 With RTU in Run Mode Using YDOC Terminal

- Open YDOC Terminal
- Connect the PC to the RTU using a Mini USB cable
- If the unit is not already in RUN mode, select it from the menu
- From the YDOC Terminal menu select **Control / Camera / Show**
  - YDOC Terminal will try to communicate with the camera - you will see a message "Initialising camera, please wait"
  - If it can't connect, you will see a message "Initialising camera failed, timeout occurred". If this happens, double check the wiring to the camera. Check also that the red LED in the bottom right corner of the PCB is coming on and check with a multi-meter that you have +5V between pins 1 and 2 of the camera connector (X5)
  - After initialisation the terminal will display "Shooting picture, please wait"
  - YDOC Terminal will transfer the image to your PC.

### 8.1.2.2 With RTU in Config Mode

This test is completed using the Config menu and may be completed in any terminal emulator:

- Open YDOC Terminal and press Ctrl A, Shift D, Ctrl M
- Select **3** for Config mode
- Select **B** Accessory Port
- Select **T** Camera Test
- The display will show and "Camera Test: the time and "Shooting
- After taking the image you will be prompted to transfer the file to your PC

- Select Control / Y Modem data transfer, then choose the folder into which the image will be saved
- Open File Explorer, browse to the directory you selected and open the image file: the file will be named with the logger name (e.g. YDOC\_152) and the image number

### 8.1.3 Displaying Images in YDOC Insights

To display images in YDOC Insights, you must configure the camera for TCP Transfer. The image files will be visible in the Assets tab. The Slide Show report can be used to view the images in a web browser via the Map page.

To add the Slide Show Report:

- obtain a copy of the report template from your distributor. The file is named “slideshow.rpt” and should be copied to the location C:\YDOC\Insights\Templates
- open YDOC Insights
- select the site to which the camera is connected
- go to the Reports, right mouse click and select New Report
- locate the slideshow report in the list and select it
- once the report has been created, make sure that the checkbox to Display the report as an icon on the Map Page is ticked
- locate the site in the RTU list, right mouse click on it and select Properties
- when the properties dialogue box displays, click on the Map tab
- drag the Slide Show icon to the desired position on the page.

When users with access to this site select the Map page, they will be able to scroll through the images.

### 8.1.4 Image Location on PC

The images transferred to Insights are saved in the Archive directory in the zip file for the RTU for the particular day:

C:\YDOC\ydocinsights\archive\ydocdatacollector\<<RTU Name>

## 8.2 Using Iridium Satellite Modems

The YDOCs can be used with an Iridium Edge satellite modem. Choose the lower cost ML-017 PCB if your unit is to be satellite only; if you want to use satellite with cellular fallback or cellular with satellite fallback, use the standard ML-417 PCB.

When using the satellite modem for upload, you can select to send all of the Logged values (for example logging every 4 hours and uploading 2 readings every 8 hours) or to send the Actual values at the time of the upload

- use Actual values to minimise the amount of data being sent
  - this is useful if you are on a minimum data plan
  - it is also an option if someone will be attending the site regularly to download the full data set from the SD card
  - you can also set a Normal Upload rate which is long (e.g. 12 hours) and then set an Alarm rate which is more frequent (e.g. 2 hours). When the parameters are within the accepted range, a single reading will be uploaded every 12 hours. But if the parameter goes in to alarm, the sensors will be read and uploaded every 2 hours
- use Logged Values if you need to upload the full, contiguous data set
  - use this in conjunction with the Compacted format to reduce the volume of data being sent.



### 8.2.1 Satellite Plan

Your provider will set the unit up on an appropriate satellite data plan  
e.g. KSAT 30kb plan

Unlike cellular plans, satellite plans only provide very small data allowances and penalties for going over the allocation are steep. As a consequence you must be careful to minimise both the amount of data sent by lengthening the connection interval and logging rates.

The provider will need the Email address to which the received data will be set. The email address for sending data to Sensori is:

Compacted Data:

toipYdoclridiumCompacted@agent.sensori.cloud

Un-Compacted Data:

[toipYdoclridiumNoncompacted@agent.sensori.cloud](mailto:toipYdoclridiumNoncompacted@agent.sensori.cloud)

## 8.2.2 Normal and Compacted Mode

The Iridium Satellite units can transmit values in normal text mode or in compacted mode. To minimise satellite data volumes, you should use the Compacted mode whenever possible.

In Uncompacted mode, keep the Tag Names and Code as short as possible to reduce the number of non data characters sent:

- e.g. for Air Temperature, set the Name and Code to AT

In Compacted mode, you can send a maximum of 15 parameters and these must be labelled as P1 through to P15

- when building your configuration, keep a list of which parameter maps to what code
- e.g. P1 = Relative Humidity, P2 = Air Temperature etc.
- you can add extra characters in the Code after the digit but these are stripped off in transmission
- e.g. P1-RH, P2-AT, P3-DPT

When the packets are constructed, the "P" is stripped off, as are any characters after the number and the values are sent in binary format. The system to which you are sending the data must be capable of unpacking the compacted data (YDOC Insights, Sensori). It also pays to turn any unnecessary Internal sensors and to reduce the number of decimal points in the tag values, to minimise overhead.

## 8.2.3 Hardware Mounting

The Iridium Edge modem is 180 x 85 x 30 mm in size and a short pigtail cable comes out on the base of the unit. The cable terminates in an M2

plug. When you purchase the modem, you must also purchase an M12 cable to bring the data in to the YDOC (See section 8.2.4).

If you are using the Iridium with the SLA charge board and a larger enclosure, the Iridium Edge modem can be mounted on the top of the enclosure. The Edge is supplied with a waterproof seal to protect against water ingress.

If you are using the standard YDOC case with LFP charge board and ML-OP-524 option board, you will have to supply your own bracket on which to mount the Iridium Edge modem. In this configuration the M12 cable must be routed into the case via a cable gland.

## 8.2.4 Connection to Telemetry Unit

The Iridium connects to the Accessory Port on the YDOC PCB (X5).

The Iridium has 2 wires for power: one which supplies the 12V and a second which turns the modem on and off. The 12V power can come from either an SLA charge board or the ML-OP-524 expansion board.

Connect the Iridium Edge Modem to the ML417/ML017 as follows:

Iridium Cable Colour		Accessory Port (X5)	Function
Iridium Cable	RS Electronics Cable		
Yellow	Yellow	Pin 5	Rx
Green	Green	Pin 4	Tx
Pink	Grey	-	External Power (12V)
Brown	Brown	Pin 2, 3 Ground	Ground
Grey	Pink	Pin 1	PWR Control

Note:

- a suitable cable tail can be purchased from RS Electronics Part Number 4504962722 or Code 8203755
- connect a 33k ohm resistor between Pins 1 and 2 on the Accessory header to ensure the modem shuts down cleanly

when not in use. If you do not do this the modem will draw 20 to 30mA continuously.

A 33 kohm resistor must be installed between the Power Control line and Ground (Pins 1 & 2 on the 5 pin Accessory connector) to ensure the Iridium Modem turns off properly when not in use.

#### 8.2.4.1 SLA Power Board

In this configuration, the Iridium receives permanent 12V power form the SLA board. The Iridium is then turned on via the 5V switched output on the Accessory port.

When using the Iridium Modem in an RTU with the SLA Charge Board, the and external 12V battery:

- connect the External Power wire from the Iridium to 12V OUT on the SLA charge board
- connect the PWR CONTROL wire to pin 1 on the Accessory port

#### 8.2.4.2 LFP Power Board and ML-OP-524 Expansion Board

In this configuration, the 5V output on the Accessory port is used to turn on the 12V output on the ML-OP-524 expansion board which in turn feeds 12V to the POWER and POWER CONTROL wires on the Iridium.

Set the links on the Expansion Board as follows:

- Output 12V
- MODE no jumpers

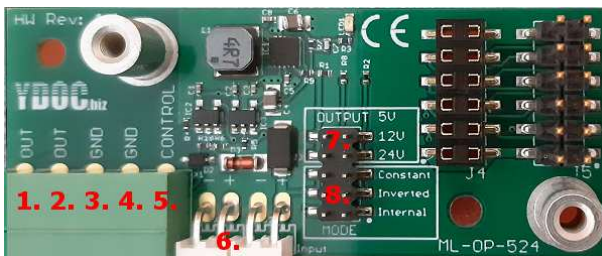

Wiring:

- connect the External Power wire from the Iridium to pin 1 OUT on the ML-OP-524
- connect the PWR CONTROL wire to Pin 2 OUT on the ML-OP-524

- run a wire from Pin 1 on the Accessory port to pin 5 CONTROL on the ML-OP-524

## 8.2.5 RTU Configuration

You now must configure the RTU to get rid of any unnecessary sensors and to set the log and transfer rates at an appropriate value for the satellite service.

Connect to the RTU using YDOC Terminal or HperTerminal and set/check the following:

- from the main menu select **3 Configuration Setup**
- go to **1 General settings** and set the Log rate (e.g. 12 hours)
- go to **B Accessory port** and select **Iridium Modem**
- make sure the port parameters are set to 19200, 8, , 1
- turn the Power switch on and select a warm up time of 30 seconds
- go to **6 Data Transpond** and select whether you want to send just the latest value (lowest amount of data) or the logged values (all values since the last transmission)
- leave the Backup mode on **Not Used (1)**
- make a list of the sensors you will have connected and the Code to use for each
  - if you are using Compact mode, allocate them a CODE starting at P1, then P2, P3 etc (up to P15)
  - if you are not using Compact Mode, you do not need to use these codes but keeping the Codes short will help reduce packet size e.g. instead of "LEV" use "L", instead of "AT" use "A" etc.
- then go to the setup for each type of sensor and add them
  - set the parameter CODE to P1, P2 etc
  - set the Sending selection according to what you wish to be sent:
    - ◆ Sending Actual Values: for each parameter you wish to transmit over the satellite, set "Data transpond" to ON
    - ◆ Sending Logged Values: for each parameter set the "Data Log" option to ON and select MODEM and SATELLITE (even if the 4G modem is not being used, you must still select that option)
- go to **7 Message format** set to **Compacted** if you are using that mode

- the Iridium system charges by the packet and on sites with a handful of parameters, the message will fit in a single packet
  - the Compacted format would reduce the message size, but as you will still be billed for the full packet, there is no saving
  - but if you have more characters that can fit in a single packet, the unit will send 2 packets: you will be charged for 2 full packets (even if you only use 1 character in the 2<sup>nd</sup> packet)
  - when this situation arises, use of the Compacted format may reduce the message size to the point where it will fit in a single packet
- go to 8 Data Output and make sure Satellite is ON for the parameter
  - continue until all parameters have been configured.

## 8.2.6 Testing in RTU

Make sure that the modem is connected as shown in section 8.2.4. Connect to the unit from YDOC Terminal:

- after activating the menu select 5 Maintenance Menu
- select 2 Com Port Terminal
- select 2 Accessory Port, Iridium Satellite
- the green LED labelled ACC which is next to the upper left corner of the 5 pin accessory header (X5) will turn on indicating the accessory port is powered up
- if you have set a Warm Up time in the modem configuration, you must wait for that time to elapse before the modem will accept commands
- type the command ATI The modem should respond with 2400.

Now you have established communications with the modem, take the unit outside where it has clear view of the sky and complete the following tests:

- first off, make sure that you have had a reply from the Iridium provider to inform you that the service is active
- enable auto registration AT+SBDAREG=1
- to check the registration AT+SBDREG?
  - 0 detached 2 Registered on N/W
- check signal strength AT+CSQ
- setup test message in buffer AT+SBDWT="helloThere"
- Initiate data session AT+SBDIX

- the response, which will appear in a couple of seconds takes the format:  
+SBDIX <status><message\_no><length><No queued messages>  
e.g. +SBDIX: 0, 20, 0, 0, 0, 0
  - look for a 0, 1 or 2 in the status to indicate a successful session
  - other codes indicate a failure: 18=lost connection, 32=no network
  - the message number should increment with each message
- clear the buffer again      AT+SBDD0
- now watch to see if an email is delivered to your email address with the test message
- the message will carry an attachment with the contents of the message. Open this to check that what you typed is what was received.

When you have finished, press Ctrl-Z to exit Com Port Terminal Mode.

When you set the unit to RUN mode, you should see a message indicating that it can communicate with the modem.

```
Running
Module power switch on
System log...WDT;Iridium Satellite
ATE0
<16:40:04>
ATE0
<16:40:19>
ATE0
READY
AT+SBDWB=42      (setup for binary transfer of 42 characters)
2
OK
READY
OK
AT+SBDI          (send message to satellite server)
+SBDI: 1,32
OK
AT+SBDD0        (message sent OK)
```

### 8.3 Using the GPS Receiver

YDOC's GPS Receiver may be fitted to the Accessory port on the RTU.

Wire the GPS Module to the Accessory connector as follows:

Function	Colour	Accessory Pin
Power	Red	1
Ground	Black	3
Rx (to RTU Tx)	Green	4
Tx (to RTU Rx)	White	5

The RTU must now be configured for the GPS:

- Connect to the RTU and activate the Menu
- Select 3 Configuration Setup
- Select B Accessory Port
- Select 3 GPS
- Go to option 3 Power Switch and Enable the Power Switch, then set the Warm Up time to 60 seconds
- Select option 4 Independent Data log is set to OFF
- select 5 Sample Interval and set the rate to match the log rate (e.g. 15 minutes)
- if you want to keep a track of how many satellites were in range, activate option F, otherwise select it and choose R to remove
- if you want to track signal strength, select it at option I or remove it if you do not want to use it.

Save the configuration and start the unit running.

You can monitor communications between the GPS and the RTU using Com Port Terminal (select the Accessory Port, RS232, 9600/8/N/1). The GPS uses the NMEA-0183 protocol and the communications are not in plain text so are hard to interpret.

If you set the unit to Run mode and monitor communications in YDOC Terminal, you can monitor the progress with readings:

```
Module power switch on
<09:15:00>
```

```
2016/06/10 09:15:00 Actual Values ML-315 Logger Version 2.3 Build 4
```

SCNT	Satellites	9	
LAT	Latitude	-34.066406	deg
LON	Longitude	137.589981	deg
MINVi	Min voltage	3.72	V
OCi	Operating cycle	900	sec
PTi	Processor temperature	27.9	C
AVGVi	Average voltage	3.8	V
AVGCI	Average current	82	mA
Data log...done			
Module power switch off			

## 8.4 Adding an NMEA Compatible GPS

The YDOC's may also be connected with an NMEA compatible GPS via the Serial port. In this case the Driver is set to "NMEA" instead of "GPS"

Many NMEA GPS units return the latitude and longitude components in the format dddmm.mmmm (degrees, minutes and fractions of minutes) with Northing & Eastings e.g. LAT 172814.0 Northing=S. This must be converted to decimal degrees. The conversion can be carried out using a Calculated Channel. The standard conventions for naming the input channels are as follows:

CGA2	Latitude	CGA3	Northing (S=South, N-North)
CGA3	Longitude	CGA4	Easting (E=East, W=West)

The formula for the conversion is written as follows:

Latitude formula (LAT):

$$(\text{floor}(:\text{GGA2}/100)+100*(:(\text{GGA2}/100)-\text{floor}(:\text{GGA2}/100))/60)*\text{eq}(:\text{GGA3};83;-1;1)$$

Longitude formula (LON):

$$(\text{floor}(:\text{GGA4}/100)+100*(:(\text{GGA4}/100)-\text{floor}(:\text{GGA4}/100))/60)*\text{eq}(:\text{GGA5};87;-1;1)$$

Create two calculated channels and copy and past the formulae to the Calculation field.

## 8.5 Expansion Boards

A number of expansion boards are available for the ML417 units. These plug in to a 12 pin dual in line (DIL) header which is on the top of the PCB. Two screws hold the board in place. Boards can be stacked on top of one another: you can stack up to 3 boards but only one of each type (Category ID or CID).

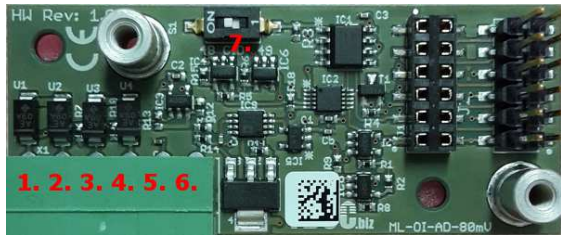

Some boards have a switch to choose a different CID, so you can stack two of the same boards

- Converter(OC) or Power (OP) boards don't have CID's and you can stack as many OC/OP-boards as mechanical feasible
- OC-boards don't make use of the internal control bus, but are wired to existing inputs/outputs/ports.

Prior to installing an expansion board, inspect the main board closely to make sure that all of the pins on the header are vertical and have not been bent. If any have been moved out of place, realign them with a pair of needle nosed pliers.

To install an expansion board:

- you may find it easier to remove the main board from the case in order to fit the expansion board
- remove power from the YDOC unit (if you have a USB cable connected, remove it as well)
- carefully slide the board down on to the 12 pin header
- remove the two screws which are stored on the offset standoffs and use them to secure the board to the main board
  - if you add a second board it will connect to the offset header pins on this board
- reconnect power to the board.
- 

To add an Expansion Board to the configuration:

- open YDOC Terminal and activate the menu
- go to option **3 Configuration**
- select option **5 Option Boards**
- from the Option Boards menu, select the type of board being used
  - you can add 2 analogue boards as OB1 and OB2. The first board should have the CID switch set to OFF and the second board should have the switch ON
  - if you are adding one analogue board, select 1 – Analogue AB1
  - then select **1 Add Board**
  - then select the board from the Board Type Menu e.g. for a 4 channel 4-20mA converter select 4
- when you save the changes, the RTU will check to see if it can communicate with the expansion board
  - if the board is not found, an error message will display on the screen
  - if the board is found, the unit will go back to the previous menu.

### 8.5.1 ML-OI-AD-80MV - Dual channel 16-bit differential input

Milli-volt amplifier board, dual input for connection to pyranometers or load-cells.

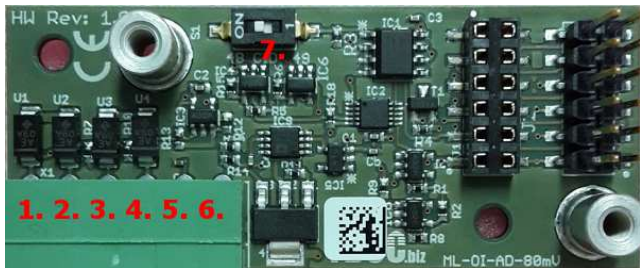

Ranges                    +/- 10mV, +/- 20mV, +/-40mV, +/- 80mV

Excitation                5V @ 80mA

Terminals	1	In 1 +
	2	In 1 -
	3	In 2 +
	4	In 2 -

- 5 Excitation
- 6 Ground
- 7 CID selector

### 8.5.2 ML-OI-AD-2000MV - Dual channel 16-bit differential input

Milli-volt amplifier board, dual input for connection to Thermistors and pH probes.

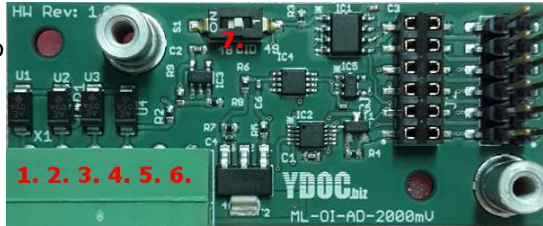

Ranges                    +/- 250mV, +/- 500mV, +/- 1V, +/- 2V

Excitation                5V @ 80mA

Terminals                1    In 1 +  
                                   2    In 1 -  
                                   3    In 2 +  
                                   4    In 2 -  
                                   5    Excitation  
                                   6    Ground  
                                   7    CID selector

### 8.5.3 ML-OI-AD-10V - Quad channel 16-bit single ended input

Four channel single ended (ground referenced) analogue input module.



Ranges                    1.25V, 2.5V, 5V, 10V

Excitation	12V
Terminals	1 In 1
	2 In 2
	3 In 3
	4 In 4
	5 Excitation
	6 Ground
	7 CID selector

### 8.5.4 ML-OI-AD-20MA - Quad channel 16-bit single ended 4-20mA input

This module provides an additional 4 off 4-20mA inputs.



Excitation	12V
Terminals	1 In 1
	2 In 2
	3 In 3
	4 In 4
	5 Excitation
	6 Ground
	7 CID selector

### 8.5.5 ML-OI-BARO - Atmospheric pressure & temperature sensor

This module adds a barometric pressure sensor to provide pressure compensation in non-vented water level sensors.

Barometric Pressure	300...1200hPa ( $\pm 1$ hPa)
Temperature	-30...+70°C ( $\pm 1$ °C)

### 8.5.6 ML-OI-COM-UART - Serial sensor input (UART)

This module is used to support the connection of TTL sensors to the RTU.



Baud Rates	300 – 230400 bps
Transmit level	3.3V
Receive Level	3.3V, 5V
Excitation	3V

Terminals	1	Excitation
	2	Tx
	3	Rx
	4	Ground

### 8.5.7 ML-OI-COM-RS232 - Serial sensor input (RS232)

This module provides for an additional RS232 port for connection to RS232 sensors such as a GPS.



Baud Rates	300 – 230400 bps
Excitation	12V

Terminals	1	Excitation
	2	Tx
	3	Rx
	4	Ground

### 8.5.8 ML-OI-COM-RS485, Serial sensor input (RS485)

Use this board to add an RS485 port for connection to MODBUS sensors.



Baud Rates            300 – 230400 bps  
Excitation             12V

Terminals	1	Excitation
	2	A
	3	B
	4	Ground

### 8.5.9 ML-OI-COM-SDI12 - SDI-12 sensor input

This board provides an additional SDI-12 port to the RTU



Baud Rates            1200 bps  
Excitation             12V

Terminals	1	Excitation
	2	Ground
	3	SDI-12 data

### 8.5.10 ML-OA-RS232 - RS232 Auxiliary board

This board provides an additional Accessory port for connection to a Camera, GPS Receiver, satellite modem or TFT display.



Output Control	Off/On: 0/3.6V
Baud Rates	300 - 230400bps

Terminals	1	Control Out
	2	Tx
	3	Rx
	4	Ground

### 8.5.11 ML-OU-BLE - Bluetooth LE user interface

This module supports remote programming and download from the RTU via a Bluetooth LE enabled portable device and the YDOC Terminal App.

Range	0 – 160 m
Transmit level	+4 dBm
Receive sensitivity	-92 dBm

To use the Bluetooth LE board and YDOC Terminal App, your phone must be running version 7 or later of the Android Operating System. After installing the APP and fitting the ML-OU-BLE board to the YDOC, you will be able to use your phone to configure the YDOC RTU.

Installation:

- carefully place the expansion board over the expansion port on the RTU, making sure the pins on the PCB line up with the holes in the socket on the BLE expansion board
- push the board down so it sits on the two posts
- fix the ML-OU-BE board in place using the two supplied 3mm screws.
- No configuration is required: the RTU will automatically detect presence of the board.

For details on using the YDOC Terminal for Android App refer to section .

### 8.5.12 ML-OC-W2P - Waveform to digital pulse converter

This board may be used to support connection of a sensor with a “coil” output to the YDOC. This type of output is found on some anemometers and flow sensors, which generate a small AC signal when a magnet passes a pickup coil.



Frequency range	0 – 50 kHz
Voltage range	60 mV to 24 V
Output	Pulse 0 – 3.6V DC

Terminals	1 - Coil In	“+”
	2 - Coil In	“-”
	3 - Pulse Out	

#### Setup:

- You do not have to add this board as an expansion module: it is operative as soon as it is plugged in
- Connect the two wires from the sensor to pins 1 & 2 on the interface
- Run a wire from Pin 3 (Pulse Out) to one of the 3 digital inputs which are on Pins 1 to 3 of X3, then add the pulse input to the configuration
- Use the Digital Input Test function to check that when your sensor operates, that the correct number of pulses is counted on the input channel.

### 8.5.13 ML-OP-524 – 300mA DC-DC Converter

This board generates a separate DC output voltage which can be used to supply power to external sensors. It may be used to provide power to accessories which require 12V power (e.g. Iridium Edge modem).

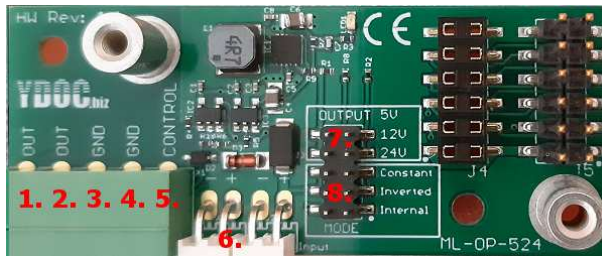

The board may be used in 4 modes, according to which position the jumpers shown as 8 in the image above, are set:

- Internal: the output turns on whenever the YDOC's internal DC sensor power switches on
- Inverted: the output turns off when the signal connected to the CONTROL input (Pin 5) turns on
- Constant: output is permanently on
- External (no jumpers fitted) : the output turns on when a signal connected to the CONTROL input (Pin 5) turns on

The output voltage is set by the links shown as 7 in the image above.

Output	5V	300 mA
	12V	200 mA
	24V	100 mA

Terminals	1	Output V
	2	Output V
	3	Ground
	4	Ground
	5	Control In
	6	Supply In (from YDOC)

The OP board gets its power directly from the batteries on the Power board. To use the board you must connect 2 off YDOC PSC cables: one from the connector J1 on the RTU PCB and a second to connect to the matching connector on the power board (e.g. LFP). The two Molex sockets on the OP board are wired in parallel so it does not matter which goes to the power board and which to the RTU board.

### 8.5.14 ML-OA-WIFI - WiFi Expansion Board

The WiFi expansion board allows the RTU to send its data over a local WiFi network rather than the mobile data network. The Modem Output settings (FTP, TCP, MQTT etc) must be disabled when the WiFi board is used. Data is sent via HTTP or MQTT to the server. When using Sensori, select HTTP output.

After plugging in the expansion board and locking it in place with the two screws, add the board to the RTU configuration:

- activate the menu and select     3     Configuration Setup
- from the config menu select     5     Option Boards
- from there select                5     Accessory Port
- from the Accessory menu select  1     Add a Board
- when prompted for board type   2     ML-OA-WIFI
- the WiFi settings screen will display. Enter the details for the WiFi network to which you will connect
- when you have entered the Access Point details, perform a WIFI Test (T)
  - if the test does not succeed go back and check that you are in WiFi range and confirm the credentials are correct.
 

```

APN test
<01:32:52>
WiFi power on
<01:32:54>
ATE0
AT&S2
AT+UWSC=0,5,2
AT+UWSC=0,100,2
OK
AT+UWSC=0,2,"toip"
AT+UWSC=0,8,"*****"
OK
AT+UWSCA=0,3
<01:32:58>
+UJWLE:0,CC40D0E50629,1
Wifi idle
APN test OK
Press any key! >
          
```
- Now go to the Modem Output menu and remove the TCP, FTP or MQTT output settings (select each and then use R to remove)
- from the Config Setup menu select   **E   WiFi Output**

- then select the transmission type and enter the details for the server to which you are sending
  - for Sensori you will need to use HTTP
  - the RTU will by default copy the settings you had in the TCP, FTP or MQTT menu so if they were already set, all you will need to do is to alter the transmission interval
  - ensure the Security type is set to HTTPS not Basic
- when you have added the server details, perform a Test
  - the modem LED on the WiFi board will turn on when the WiFi unit is active
- save the configuration and set the unit to RUN mode.

### **8.5.15 ML-OI-AX-DS18B20 4x 1-Wire Digital Thermometers**

The ML-OI-AX-DS18B20 allows you to connect up to 4 temperature sensors which use the DS18B20 I2C sensing chip. The sensors connect via a 1 Wire interface.

Although 1-Wire supports the connection of multiple sensors on the same 1-Wire cable/bus, to keep things simple, the board uses 4 separated 1-Wire inputs.

#### **Specifications**

- Protocol: 1-Wire (Maxim Integrated)
- Number of channels: 4
- Excitation: 3.6V DC
- Supported chips: DS18B20, as well as DS1820, DS18S20, DS1822 & DS1920

To install the board, power down your YDOC and then plug the board on to the expansion connector. Secure it in position using the two screws.

Connect your sensors to the inputs:

Red 3.6V

Black GND

Yellow Sensor CH 1 to 4

Power the board and connect via the USB port.

Activate the Configuration Menu and select 5 Option Boards

From the Option Boards menu select 6 Auxiliary Inputs

The YDOC will have recognised the addition of the board and it will be listed against menu item 1

Select option 2 Auxilliary Input driver and configure the sensors

- select options 4, 5, 6 and 7 and set the parameters for each sensor

Once you have connected the sensors, select Option T to make a test measurement: confirm that each of the connected sensors is returning sensible values.

## 9 Other Functions

### 9.1 Erasing an RTU Configuration

If you want to quickly restore an RTU to the default settings, you can erase or delete the configuration:

- At the main menu select **5 Maintenance**
- From the Maintenance Menu select **9 Bootloader Menu**
- when prompted select “Y” to confirm that you wish to invoke the Bootloader menu
- disconnect and then reconnect the terminal session
- from the Bootloader Menu select **E Erase Config**
- after the configuration has been cleared, select R to return to the normal program.

### 9.2 Changing the Order of Parameters

The YDOC units will write the measurement values to the log file in a default order. The internal sensors are first, followed by pulse, analogue and the Serial sensors, then finally the calculated channels. However some servers require the parameters to be set in a specific order. When you are using an RTU with the TFT display, you may also wish to change the order so the most frequently viewed parameters are shown first.

If needed, the order of the parameters can be changed. To do this:

- from the Main Menu select **4 Parameter Overview**
- then from the Parameters menu select **1 Parameter List**
- when the list of parameters displays, select the sensor whose order you wish to change by typing the number that appears next to its name
- when prompted, assign it a new order
- continue until all of the tags have been re-ordered
- review the order again to make sure it is correct then make a backup of the configuration from the Maintenance Menu.

### **9.3 *Exporting to Sentek IrriMax***

If you configure the RTU to use the FTP export format, you can send the data to an FTP server from where it can be uploaded in to IrriMax.

Note that the IrriMax FTP uploader requires a fixed file name whereas the default for YDOC is to write a new file each log and to append the time stamp to the file.

To set up an RTU for IrriMax:

- configure the RTU as normally i.e. log interval, Sentek probe setup etc.
- go to the FTP configuration options
- set the Server address and port to match the FTP server
- set the user name and password allocated by the owner of the FTP server
- if you want to nominate a particular folder to write the file to, set the name in the Directory option (9)
- select option A – Omit Timestamp then when prompted select 1 for Yes
- the exported files will be allocated the RTU name only

When using this function, to ensure that you do not miss any readings, make sure that IrriMax is searching for an updated file at least twice as often as the RTU is sending them.

## 9.4 Manual Download

Information capture in the logger can be manually downloaded. This allows you to examine the RTU's logs to help diagnose problems and also to transfer captured readings to a text file. You may need to do this if you lose mobile data comms and need to transfer the data to the server manually.

To perform a manual download:

- From the menu select **5 Maintenance**
- From the Maintenance Menu select **3 Data Download**
- When prompted the start date and time, end date and time, date format and file format.

Data download

Start date or <CR> for this day (YY/MM/DD): 15/09/18

Start time or <CR> for midnight (hh:mm:ss):

End date or <CR> for this day (YY/MM/DD): 15/09/24

End time or <CR> for midnight (hh:mm:ss): 10:00:00

Download data from 2015/09/18 00:00:00 till 2015/09/24 10:00:00

Data format (0 = Native(txt), 1 = CSV(.,), 2 = CSV(,:)): 1

Date format (0 = YYYY/MM/DD, 1 = DD/MM/YYYY, 2 = MM/DD/YYYY): 0

When prompted for the data format make you selection as follows:

- Diagnostic purposes: select "0" for Native Format
  - This captures the logger status information (lines prefixed with "S") and the data (lines prefixed with "D")
- To capture data for importing to another program: select "1"
  - This will send the data records only
  - The data will be sent in comma delimited form using "." as the decimal point (do not use Option 2 as this will send the data with a comma for decimal point and a colon separator)
  - There are two header rows at the start of the file which show the column names
- For use with YDOC Insights, select Native format
- The file will be saved with the name of the logger
  - If you have selected native format the file will be saved as a .TXT file but if you select 1, it will be saved as a .CSV file

A prompt will then display asking you to commence a Y-Modem transfer of the file to your PC. In HyperTerminal select **Transfer / Receive File**.

Once the transfer completes, go to the folder in which your terminal program saves transferred files. You can then examine the file or transfer it to YDOC Insights or another program for analysis.

## 9.5 Firmware Upgrade (Direct Connected)

The RTU firmware can be upgraded via the USB Port or via a remote connection. The latest firmware is always available from the YDOC Web site:

<https://www.ydoc.biz/datalogger-firmware.html>

Download the latest firmware and save it in a suitable location on your PC. To see what changes have been made in each version, you can view the update log:

<https://www.ydoc.biz/datalogger-version-changes.html>

To upgrade the firmware when direct connected to the RTU:

- Connect to the RTU using a terminal emulator
- Activate the menu **Ctrl-A Shift-D Ctrl-M**
- Select Maintenance **5**
- Select Firmware Upgrade **7**
- You will then be prompted to upload the file using the Y-Modem protocol
  - The screen will display “CCCC...” while it waits for the file transfer
- Select Send File and then select the file from the location in which you saved it.
- When the transfer finishes, the RTU will re-start: disconnect and your terminal program and wait for 30 seconds
- Connect to the RTU, activate the menu and verify that the new firmware version is shown at the top of the menu page.

## 9.6 Remote access and upgrades

The YDOC RTUs may be accessed remotely in order to modify the configuration, test attached sensors, replace the configuration or upgrade the firmware.

Remote access is gained using the functionality built in to the RTUs and to YDOC Terminal. In the simplest form, this takes the form of remote TCP connections, but may also be through a scheduled remote connection, a remote configuration update, or a remote firmware update. These functions rely on the RTUs checking for the presence of any of the following files when it connects to the server to send data:

- YDOC\_<Serial No>.tlr Remote connection request
  - contains the details of a Scheduled Remote Connection session
- YDOC\_<Serial No>.cfg Configuration file
  - the RTU will upload the new configuration
- YDOC\_<Serial No>.bin Firmware file
  - the RTU will upload the new firmware.

## 9.6.1 Remote Access via TCP

Using the credentials the RTU uses to send data to the Server (YDOC Insights or YDOC Java Data Collector) you can create a remote connection to an RTU using the YDOC Terminal program. You can also save the connections for later use.

To setup remote access to an RTU:

- Open YDOC Terminal
- Select File / New / TCP-Socket Connection
- When the session properties display, configure the connection
  - IP Address: local or remote IP address of the Insights server
  - Port: the port assigned to TCP connections on the server (typ 37)
  - Serial Number: The Serial Number for the logger you wish to connect to (e.g. 5900152)
  - User name: The user name to log on to the server with
  - Password: The password for the account
- After checking the details, select OK, then use File / Save to save the session with a suitable name e.g. Remote access 5900152.

### 9.6.1.1 Opening a saved remote session

Open YDOC Terminal and using the File Menu, open the session you created for this RTU.

When YDOC Terminal opens the session, it will log in to the server using the credentials saved in the configuration file

- If the login was successful, the screen will display a message indicating the time remaining until the next connection is expected to be made
- When the RTU connects to the server, it will stay on line. When the Terminal session is closed, the RTU will shut down and go back to its normal poll schedule.

When the RTU comes on line, you can access the command menu in the same manner as if you were directly connected

- If you make any configuration changes, make sure that you put the RTU back in to RUN mode before closing the session (if you forget, the unit will not log any data)
- Make sure that you allow plenty of time after selecting a command as the units can be quite slow to respond.

## 9.6.2 Scheduled Remote Connections

YDOC Terminal supports connections to RTUs which are retrieving data via TCP, FTP, MQTT or HTTP. These make use of a Secure Tunnel Server operated by YDOC.

When the RTU connects to the server it always checks for the presence of the “tlr” file. If one is found, the unit stays on line and waits for the connection. The connection is not made directly from the RTU to YDOC Terminal, rather it is made from the RTU to the Secure Tunnel Server and from there to YDOC Terminal. Data travelling between your PC and the RTU is encrypted to keep it secure.

To setup a Secure Tunnel Server connection using YDOC Terminal:

- open YDOC Terminal
- select File / New / Schedule a Remote Connection
- the Tunnel Server dialogue box will open
- Data Logger S/N Enter the ID of the unit you wish to connect to
- Date / Time select the time for the connection
- in the Server Properties section, select the Type of Server to which the data is sent
  - the options include FTP, MQTT, HTTP and TCP
  - the properties for that type of connection will then show
  - if you are using the YDOC Secure Tunnel Server, the details should be entered as shown below:

- server address      tunnel.ydoc.biz
- port                    37
- access token        yTunnel
- enter the credentials used for the connection
- When you have filled out the relevant fields, click on the SCHEDULE icon to queue the connection
  - the connection time must be at least 2 minutes ahead of the current time to allow sufficient time for the TLR file to be sent to the server and for the tunnel server connection to be prepared

Schedule a remote connection through a secure encrypted tunnel

Data logger S/N:  ... Schedule a remote connection at: Thursday, 28 November 2015 11:00:00 AM

Schedule remarks:

Data collector server properties (server where the data logger transfers its log files to)

Type of server: tcp:// Server address and optionally TCP port: 120.150.31.37

User: toip Password:  host[:port]

Scheduled at	Logger S/N	Remarks

- Once the remote connection request file has been placed on the server, the connection request will be shown on the bottom of the Remote Connection Schedule screen.

Scheduled at	Logger S/N	Remarks
 10:45:00 16-Jul-2020 Expected in: 00:05:58	99017537	

- Shortly before the connection is due, a new Terminal Window will open in readiness for the connection
- when the device connects, this window will activate and you can then access the Menu system for the RTU.

When using Sensori, the FTP credentials are the same as those used for sending data. In the "Type of Server" list box choose ACTIVE FTP

### 9.6.3 Remote Configuration Updates

You can update the configuration in an RTU remotely via YDOC Terminal:

- select Tools / Remote Configuration Update
- from the list of protocols which display, select the method being used by your RTUs
  - for Sensori for instance, you will select FTP (if you have the devices sending to an FTP server but are using TCP for a remote heartbeat, you can use TCP for the update)
- YDOC Terminal will then show a window with a list of the available RTUs
  - if you have not used the list function previously, the list will be empty
  - if you have been using Scheduled Remote Connections, the list will hold details for any RTUs you have connected to previously
- to add RTUs to the list, click on ADD. A new line will be added to the table
  - Fill in the details for the RTU: Logger SN and Station Name as a minimum. I past the credentials in to the Remarks section so that I can copy them from there to the User Name and Password in subsequent remote sessions
  - in the Server Settings at the bottom of the window, enter the details for the server (URL, Port, User Name and Password)
- at the top of the screen, click on the "..." button on the right of the CONFIGURATION FILE and select the configuration file you wish to upload to the RTU
- now click on the UPLOAD button
- now go back up to the list and activate the checkbox alongside the RTU you wish to update
- when you click on SAVE the files will be sen to the server and the devices will update when they make their net scheduled connection.

### 9.6.4 Remote Firmware Updates

You can update the firmware in an RTU remotely via YDOC Terminal:

- select Tools / Remote Firmware Update

- from the list of protocols which display, select the method being used by your RTUs. For Sensori for instance, you will select FTP (if you have the devices sending to an FTP server but are using TCP for a remote heartbeat, you can use TCP for the update)
- YDOC Terminal will then show a window with a list of the available RTUs
  - if you have not used the list before, the list will be empty
  - if you have been using Scheduled Remote Connections, the list will hold details for any RTUs you have connected to previously
- to add RTUs to the list, click on ADD. A new line will be added to the table
  - Fill in the details for the RTU: Logger SN and Station Name as a minimum. I past the credentials in to the Remarks section so that I can copy them from there to the User Name and Password in subsequent remote sessions
  - in the Server Settings at the bottom of the window, enter the details for the server (URL, Port, User Name and Password)
- at the top of the screen, click on the "..." button on the right of the FW FILE and select the firmware file you wish to upload to the RTUs
- now click on the UPLOAD button
- depending on the protocol being used, YDOC Terminal will then clone the firmware file multiple times, renaming each instance with the ID of the device to be updated
- now go back up to the list and activate the checkbox alongside all the RTUs you wish to update
- when you click on SAVE the files will be sent to the server and the devices will update when they make their net scheduled connection.

## 9.6.5 Recovering After a Failed Upgrade

In extremely rare conditions, an upgrade may fail, leaving the PCB without firmware in its non-volatile memory. It will then get stuck in a continual "boot loop" where it re-starts, tries to load its firmware, fails and re-starts.

You can force a firmware reload as follows:

- power down the YDOC and remove the Micro SD card
- make a copy of the current firmware and re-name it to restore.bin
- copy this file to the Micro SD card
- place the card back into the PCB

- apply power to the board and allow it to re-start
- the board will load the firmware and return to operation.

If you have any problems with this process, return the PCB to TOIP.

## 10 Setup for Specific Sensors

The following section gives information on how to configure and use the YDOC RTUs with specific sensors.

### 10.1 Rika RK510 Soil Moisture Sensor

The RK510 is a single level soil moisture sensor which measures moisture content using a fixed frequency SWR technique.

Sensor Wiring

Connector	Pin	Function	Wire Colour
X2 (6 pin connector)	3	A	Yellow
X2	4	B	Green
X2	6	Ground	Black
X4 (3 pin connector)	1	12V	Red

The Default MODBUS address for new versions of the probe is 1. But for old versions of the probe is 0xFF (255) which is outside of the range accepted by the YDOC unit. The address must thus be changed prior to connecting the sensor. This can be carried out using MODBUS POLL (the un-licensed version will run for only 10 minutes at a time)

- connect the sensor to your PC using a USB to RS485 converter
- download and install Modbus Poll (you cannot use the Projex Modbus program for this function as it will only recognises addresses up to 254)
- run Modbus Poll
- select Connect and when prompted for the license select Register Later (or register and pay for a license)
- set the COM port parameters to 9600, 8, N, 1 and the mode to RTU
- select Setup / Read Write definition
- set the Slave ID to 255
- Set the Function to 03 – Read Holding Registers

- Set the Address to 0
- Set the Quantity to 1
- verify that when you put your hand on the sensor the reading changes (the value = 10 \* SM)
- Now to change the address (in this case to 3 which is 0x33 or 51 decimal) select **Functions Test Centre**
  - in the text box type in the following  
00 10 00 01 00 01 02 00 33 EA 04  
(each pair of digits is separated by a space)
  - this will send the command to change the address to 0x33
  - click on Send
  - the bottom window will then echo your text followed by the sensor response:  
002-Tx:00 10 00 01 02 00 33 EA 04  
003-Rx:00 10 00 01 00 01 51 D8
  - note that the EA04 is the CRC for the values with address 33. If you want to use a different address, delete the last two bytes and enable the “Add Check” and “CRC” buttons so that the program will calculate the CRC for you
  - you can verify that the Slave address has been sent by typing:  
00 03 00 01 00 01
  - the unit will echo your command (with CRC attached and the sensor response:  
04-Tx:00 03 00 01 00 01 D4 1B  
05-Rx:00 03 02 00 33 C5 91  
(in the above line 33 is the slave address)
  - close the Functions Centre and select Setup / Read Write Definition
  - change the address to 1 and make sure you still have the Function set to 03 – Read Holding Register, the Address set to 0 and the Quantity to 1
  - verify that the unit connects (i.e. you do not see a Timeout) and that the value changes when you place your hand on the sensor.

You can now connect the sensor and configure the RTU.

Connect the RTU to a PC and activate the Menu. Go to the Configuration menu and select

- at the Serial Port menu select

Serial Port (A)  
RS485 2

- in the MODBUS Sensor setup set the Name to RK510 at option 1
- select Port Settings (2) and set the Mode to RS485
- then select a Baud Rate 9600 (3)
- set the address to 51
- ensure the Power Switch (3) is enabled and set the warm-up period to 1 second
- leave the Sample Interval at the Data Log Interval
- at (5) set the Protocol to RTU
- options 6, 7 and 8 can be left at Not Used
- at option 9, set the Register Type to Holding (3)
- at Option A set the start register to 0
- at Option B set the Data Type to Word
- then select Option C and set the values at parameter 1 to suit the sensor
- set the Name to Soil Moisture
- set the code to SM010
- set the units to %
- set the Value factor to 0.1 (because the sensor outputs SM% \* 10)
- save the changes
- start the unit logging.

To check the sensor values:

- allow the unit to run for at least one log period (you can increase the log rate to make this happen faster)
- click on the Actual Values icon in the menu (Hash symbol) or at the menu prompt type Ctrl A Shift V Ctrl D to activate the Actual values display
- check that a value is displayed against the SM010 entry
- if this still does not show a value (i.e you see “No Response”) you will need to try COM Port Terminal Mode and set Modbus Poll up to use the COM port used by YDOC Terminal (Refer Section 10.8 ).

## 10.2 Rika RK520 Soil Moisture Sensor

The RK510 is a single level soil moisture sensor which measures moisture content, soil temperature and soil conductivity.

### Sensor Wiring

Connector	Pin	Function	Wire Colour
X2 (6 pin connector)	3	A	Yellow
X2	4	B	White
X2	6	Ground	Black
X4 (3 pin connector)	1	12V	Red
X2	6	Mode Setting	Green

### Note:

- early sensors had the extra Green wire to change mode. New sensors only have the 4 primary wires and no green
- to change the address on an early sensor, apply 5V to the Green wire then send the address command command
- on later sensors, simply send the command to change the address e.g. to change a sensor from address 1 to 2:  

```
01 06 02 00 00 02 09 B3
```

  - : where 09 B3 is the checksum generated from the earlier bytes and the 02 shown in bold is the new address
  - : if using a different address, generate new checksum (Modbus Poll will do this for you)

The Default MODBUS address for the sensor is 0x01.

Prior to using the sensor you can test communications to the sensor from YDOC Terminal's MODBUS Emulator:

- once connected to the RTU, select Tools / MODBUS Terminal
- set the Device address to match the sensor e.g 1
- set the Register Type to Holding register
- select Address and set this to 0
- select Data Type and select Signed Short



- at Option A set the start register to 0
- at Option B set the Data Type to Signed (Short)
- then select Option C and set the values at parameter 1 to suit the sensor
- set the Name to Soil Temperature
- set the code to ST010
- set the units to C
- set the Value factor to 0.01 (because the sensor outputs ST \* 100)
- save the changes
- start the unit logging
- now repeat for the Soil Moisture and EC
  - SM units = %, Value factor 0.01
  - EC units = mS/cm, Value factor = 0.001.

To check the sensor values:

- allow the unit to run for at least one log period (you can increase the log rate to make this happen faster)
- click on the Actual Values icon in the menu (Hash symbol) or at the menu prompt type Ctrl A Shift V Ctrl D to activate the Actual values display
- check that a value is displayed against the SM010 entry
- if this still does not show a value (i.e you see “No Response”) you will need to try COM Port Terminal Mode and set Projex Modbus up to use the COM port used by YDOC Terminal (Refer Section 10.8 ).

### 10.3 Analogue Level

A typical Analogue Water Level sensors provide a 0-5V signal proportional to level over a the depth range (e.g. 0 to 2m). They must be used with the MLx17ADS-xx RTUs.

Wiring (for Analogue 3)

X1 (8 pin connector)	Pin 3	AN 3	Yellow
X1	Pin 5	GND	Green
X4 (3 pin connector)	Pin 1	12V	Red

Connect the RTU to a PC and activate the Menu. Go to the Configuration menu and select

#### **Analogue Sensors 7**

- Select the channel Port 3 (V) 3
- Set the sensor name Name 1
- Select option 2 and set the sensor power switch to On with a warm up time of 2 seconds
- Select option 5 to edit the analogue sensor parameters
  - Set the Name to Level
  - Set the Code to WL
  - Set the units to m
  - Set the value factor 1
  - Set the offset to 0
- Select option 6 and set the value at 0V to 0
- Select option 7 and set the value at 10V to 4m (i.e. 5V at 2m)
- Save the changes
- Select the Analogue Input Test T
  - Place the sensor in a test tank and verify that the voltage readings change in line with the sensor depth.

## 10.4 Aquamonix/Pentair PT05

The PT05 10.10 pressure transducer, which has a range of -100 to 100 kPa, may be fitted to an Irrrometer Tensiometers to produce a logging tensiometer. As the RTU has 2 off 4-20 mA channels, you can connect two PT05 sensors.

Connect the PT05 to the 4-20 mA channels on an MLN315ADS RTU as shown below:

Wiring (for Analogue 3)

X1 (8 pin connector)	Pin 1	AN 1	Sensor 1 Blue
X1	Pin 2	AN 1	Sensor 2 Blue
X1	Pin 5	GND	Black
X4 (3 pin connector)	Pin 1	12V	Red

Connect the RTU to a PC and activate the Menu. Go to the Configuration menu and select **Analogue Sensors** **7**

- Select the channel Port 1 (mA) **1**
- Set the sensor name Name **1**
- Select option 2 and set the sensor power switch to On with a warm up time of 2 seconds
- Select option 5 to edit the analogue sensor parameters
  - Set the Name to Tension xxc m
  - Set the Code to IRR
  - Set the units to kPa
  - Set the value factor 1
  - Set the offset to 0
- Select option 6 and set the value at 4 mA to **-100**
- Select option 7 and set the value at 20 mA to **100**
- Save the changes
- Select the Analogue Input Test **T**
  - Connect the sensor to a tensiometer
  - From the menu select Maintenance (5) / Field Testing (1) / Analogue Input Test (2)
  - verify that the current reading is sensible: -50 kPa = 8 mA; 0 kPa = 12 mA

## 10.5 InSitu LevelTroll 400

The LevelTroll 400 and 500 sensors provide a MODBUS output. They can be used only with the ML315ADS-xx RTUs. Refer to the InSitu MODBUS manual for details on the register addressing and cabling.

Before connecting the sensor use the “WinSitu” utility to configure the sensor for the desired units.

### Wiring

X2 (6 pin connector)	Pin 3	RS485A (+)	Blue
X2 “	Pin 4	RS485B (-)	Green
X2	Pin 6	GND	Black
X4 (3 pin connector)	Pin 1	12V	Red

The LevelTroll 400 & 500 can return 3 parameters: pressure, temperature and Level. You can choose to retrieve one, two or all three of these. Each requires a separate sensor to be setup.

- Connect the RTU to a PC and activate the Menu
- From the Configuration menu select **A** *Serial Sensors*
- Select Option **2** RS485 sensors
- at the RS485 menu select **1** Generic MODBUS
  
- From the MODBUS/RTU Sensor Menu, Set the sensor name  
Name **1** (e.g. LevelTroll)
- Select Port Settings **2**
  - Select Option 2 Port Settings and select option **8** (RS485 **8E1**)
  - Select Option 3 and select **G** 19200 baud
  - Select Option 4 and set the Address to **1**
- Select Option 3 Power Switch and set Power Switch **ON** with a warm up of 2 seconds
- Select Option 4 and set this to Data Log Interval
- Select Option 5 and select a protocol of RTU
- select Option 9 and select Register type of **3** Holding
- Select Option A and set the Register Starting Address to **38**
- Select Option B and set the Data Type to **7** Float 4 Bytes
- Select Option C and set the sensor parameters
  - Set the Name to Pressure
  - Set the Code to PRES
  - Set the units to kPa

- Set the value factor      1
- Set the offset to            0
- as this parameter is not going to be sent, select option 7 Data Log and select 0 (off)

Repeat this setup for the second parameter (D) for the Temperature (Register 46)

- once again make sure option 7 is set for Data Log Off (0)

Now set up the third parameter (E) which is the Level (Register 54)

- set the Name of the Level register to distanceToWaterLevel
- set the Code to      LEV
- set the units to      m
- ensure that for this sensor, option 7 Data Log is set to ON (1)

Save the changes.

Connect the Sensor and perform a test measurement by select Option T from the MODBUS Sensor Menu.

Place the sensor in a test tank and verify that the readings change in line with the sensor depth.

## 10.6 Leeg LMP633 4-20mA 2 wire

These instructions are for the Leeg LMP633 in 4-20mA, 2 wire configuration.

Connect the sensor as follows:

Wiring (for Analogue 3)

X1 (8 pin connector)	Pin 1	AN 1	Black
X4 (3 pin connector)	Pin 1	12V	Red

Connect the RTU to a PC and activate the Menu. Go to the Configuration menu and select **Analogue Sensors 7**

- Select the channel Port 1 (A)      1
- Set the sensor name Name      1
- Select option 2 and set the sensor power switch to On with a warm up time of 2 seconds
- Select option 5 to edit the analogue sensor parameters
  - Set the Name to                      Level
  - Set the Code to                      WL

- Set the units to m
- Set the value factor 1
- Set the offset to 0
- Select option 6 and set the value at 4mA to 0
- Select option 7 and set the value at 20mA to 5m (alter to suit max depth rating of sensor)
- Save the changes
- Select the Analogue Input Test T
  - Place the sensor in a test tank and verify that the voltage readings change in line with the sensor depth
  - check the depth to water and verify that the reading is correct (convert for 4mA=0, 20mA = max range).

## 10.7 Sentek EnviroSmart Sensors

Before connecting the EnviroSmart probe to the YDOC, connect it to your PC using the Sentek TTL Cable and access the probe using the Sentek Intelligent Probe Configuration Software.

Set the probe as follows:

- Address 1
- Mode ASCII
- Baud rate 9600
- Parity Even, 7 Data Bits, 1 Stop bits

In the Sensor Configuration Tab, make sure that the number of sensors and depths coincides with the physical sensors on the probe. Use the Sensor Test function to confirm that all sensors are working and returning sensible values.

Connect the Probe to the YDOC as follows:

Function	Interface	YDOC
Power	Pin 1	X4 Pin 1
Ground	Pin 4	X4 Pin 3
RS232 Mode		
RS232 TX	Pin 5	X2 Pin 2
RS232 RX	Pin 6	X2 Pin 1
RS485 Mode		
RS485 A	Pin 5	X2 Pin 3
RS485 B	Pin 6	X2 Pin 4

In the Configuration select Serial Port and set mode to either RS232 or RS485 depending on the settings for your probe. You need to add a Sensor for each type of measurement you are going to record. For instance if you are measuring soil moisture, soil temperature and EC, you need to add 3 Sensors, each with a different Start Register address.

Set the serial port as follows:

- Port Settings RS232 or RS485 at 9600 7 E 1
- Address 1
- Sensor Power Enabled, warm up time 5 sec
- Protocol Type ASCII
- Measurement Command
  - Start measurement command Register 0
  - Value SM = 2, EC = 3, ST = 4, RH = 5
  - Ready status Not used
  - Ready after typ 2 sec but may need to try higher values
- Register Type Input
- Start Register
  - Soil Moisture (SM) 256
  - EC (EC) 320
  - Soil Temperature (ST) 384
  - Probe Humidity (RH) 448
- Data Type Float Reversed (4 Bytes IEE754)
- Parameter settings: add a parameter for each sensor depth and set the name, code and units as per the naming convention shown earlier in this manual

Probe Humidity: if you are using the Probe Humidity sensors, set the Value factor to 0.001 to scale the raw value back to 0-100 and set the Number of Decimal Places to 1.

When you have completed the parameter setup, perform a Test Measurement (T).

## **10.8 Testing MODBUS Sensors**

As the MODBUS protocol makes use of binary codes with each line ending with a pair of error checking characters, it is difficult to read and interpret the flow of characters to and from the sensors. Instead, you can use YDOC's MODBUS testing software (Projex MODBUS) in conjunction with the YDOC Terminal program to make manual readings.

If you have not already done so, obtain a copy of the Projex MODBUS software and install it on your PC.

Now use Com Port Terminal to take a reading

- open Projex MODBUS
- set the Port to that used by the RTU
- set the data rate to match the sensor
- set the MODBUS Slave address to match the sensor
- set the Register type to match the sensor
- set the Polling interval to 2000 (2 seconds)
- temporarily disconnect but do not close the program
- open YDOC Terminal and connect using the COM Port, but with the speed set to 9600
- From the Main Menu select 5 Maintenance
- Select 2 Com Port Terminal
- Select 1 Serial Port
- From the Port Mode options select 2 RS485 8N1  
(change comms settings to suit sensor)
- From the baud rate menu select g 9600 (change speed to suit sensor)
- once COM Port Terminal has started, close YDOC Terminal
- select Projex MODBUS again and click on Start to begin scanning the RS485 line
- watch to see if the registers are successfully read
- note that if there is no activity for a while, COM Port Terminal on the RTU will time out (indicated by the Output Power LED turning off again) and you will have to open YDOC Terminal and activate it again.

# 11 Diagnostics

## 11.1 Diagnostic LEDs

The RTU is fitted with a number of LEDs which illuminate when specific functions are performed.

LED	Colour	Location on PCB	Function
Modem ON	Orange	Beneath USB socket	Indicates that the Modem is on <ul style="list-style-type: none"><li>- Connection to server</li><li>- Signal strength test</li><li>- APN login test</li><li>- TCP test</li></ul>
PS ON	Red	Bottom right corner	Indicates that the switched 12V power to the sensors is turned on <ul style="list-style-type: none"><li>- Scheduled sensor read</li><li>- Direct SDI-12 commands (Comport Terminal)</li></ul>
LED 3	Green	On LHS of modem	Indicates activity on the USB port

## 11.2 Check Power Supply

The RTU is made up of two units: the Main PCB (which sits in the base of the case) and the Power PCB (incorporated in to the lid). The 3 variants of the Power PCB connect to the Main PCB using a two pin connector. Regardless of which variant is used, the voltage across the connector should be 3.6 to 4.5 volts

- Disconnect the plug from the connector on the Power PCB
- Connect a DVM between the two pins and check the voltage
- If it is lower than 3.6V:
  - If using the solar unit, remove the AA batteries and charge them in a suitable charger. Alternatively fit new, charged batteries and re-test
  - If using the Lithium battery version, remove the battery from the holder and check the voltage

- For setup and testing you can also power the RTU from a regulated 4.5V DC plug-pack.

### 11.3 Modem Diagnostics

If you are having troubles with a unit connecting, you can use the Modem command mode from the maintenance menu to send commands direct to the modem to check signal strengths and whether the unit is connecting to the GSM network.

From the Main Menu:

- Select **5** Maintenance
- Select **2** Com Port Terminal
- Select **M** Modem
- The RTU will then go in to direct command mode for the modem
  - Note that the commands you type are not echoed on the screen

Turn on full error reporting **at+cme=2**

Display full cell info with network registration **at+creg=2**

To check signal strength **at+csq**

Returns csq <signal strength>, <error rate>

- The first number is the signal strength
  - 0 < -113 dBm
  - 2 – 30-109 to -53 dBm (2 dBm per step)
  - 31 > -51 dBm
  - 99 not detectable

```
at+csq
+CSQ: 99,99      No signal
```

```
AT+CSQ
+CSQ: 31,99     Good signal strength
```

To check the pin status **at+cpin?**

- The unit will display the status of the SIM which should be "Ready". If not, check that the SIM is OK and that no PIN is set by placing it in a normal phone
- ```
at+cpin?
```

```
+CPIN: READY
```

To check the available networks

**at+cops?**

- This command shows  
at+cops?

+COPS: 2

To check for GSM network registration

**at+creg?**

- 0,0 not registered & no networks
- 2,2 searching
- 2,1 registered

at+creg?

+CREG: 2,0

Not registered

AT+ CREG?

+CREG: 2,1,"A550","32E0AC3",2

Registered on NextG

OK

## **11.4 Connection Issues**

### **11.4.1 YDOC Terminal Session Errors on Connection**

A corruption in the data on the SD card can cause a problem when remote connecting to an RTU. This is evident as the screen displaying the data records rather than the menu. You will need to connect and copy the termination characters to the RTU to stop this:

- open a text editor e.g. Notepad++
- copy the text ACK+TLR to the file then press ENTER at least twice
- save the file in case you ever need it again
- copy the text, including the new line to your clip board (Ctrl+C)
- open the remote connection to the unit
- as soon as the unit connects, right mouse click and select PASTE
- repeat this as quickly as you can until the menu activates
- if the session times out, try again on the next connection
- once you have menu access, format the SD card
  - if you want to try and recover the data, you can go to the Maintenance Menu and download the data for the period from when the error started. You can then edit the file and delete the erroneous record, before manually uploading the file.

## 11.5 Diagnostic Messages in the log file

The RTUs write two types of entries to the data file on the Micro SD card in the file datalog.txt: Data or D records and System or S records. The S records are used to signal error conditions such as low battery, failure to read a sensor etc.

If you are transferring data using TCP or are using FTP with the data sent in YDOC Native format, you can view both the S & D entries in the data file. However if you are using ASCII or CSV modes, the S records are not written to the downloaded data file.

To view the S records, either

- perform a download in YDOC Native mode
- if you have access to the YDOC Insights server, locate the archive files for the device. In that folder you will find a sub folder for each RTU. These are named in the format YDOC\_<RTU Name>\_<RTU Serial Number>. Within each sub folder you will see a daily zip folder which holds compressed copies of each downloaded file. You can then copy the files for the relevant period to your PC for analysis
- or copy the datalog.txt from the Micro SD card to your PC

| CODE         | Text                | Meaning                        | When / Causes                                                    |
|--------------|---------------------|--------------------------------|------------------------------------------------------------------|
| SYS_START    | "System name & S/N" | System is started and deployed | At power on, or reset                                            |
| SYS_DEPLOYED | "System name & S/N" | System is deployed             | After a delayed deployment                                       |
| SYS_UPGRADED | "System name & S/N" | Firmware upgrade detected      | After firmware upgrade                                           |
| CFG_CHANGED  | "System name & S/N" | Configuration has changed      | After configuration editing                                      |
| CFG_ERR      |                     | Configuration error            | Firmware downgrading, or configuration upload with wrong version |
| NO_CFG       |                     | No configuration               | Data logger is not                                               |

|         |                    |                                                                     |                                                                                                      |
|---------|--------------------|---------------------------------------------------------------------|------------------------------------------------------------------------------------------------------|
|         |                    | detected                                                            | yet configured                                                                                       |
| CFG_UPL | "cause of failure" | Configuration upload failed                                         | Disruption in the data transfer, or SD card failure                                                  |
| FW_UPG  | "cause of failure" | Firmware upgrade failed                                             | Disruption in the data transfer, or SD card failure                                                  |
| PVD_DIP | "number"           | Power voltage detection dips                                        | When the internal power (temporarily) drops unexpectedly below 2.9V and is restored before power off |
| SD_FAIL | "number"           | Number of temporary SD card failures                                | SD card failure                                                                                      |
| NETWORK | "fallback;2G"      | Network fallback (only for 2G+3G Modems)                            | When 3G network is not available                                                                     |
| WDT     | "Sensor name"      | Shows the sensor driver name where the watchdog timeout occurred    | Sensor defect, or wrongly connected, or warm-up time too                                             |
| WDT     | MODEM_INIT         | Watchdog timeout while initializing Modem                           | No response from Modem, or no SIM, or SIM not detected, or PIN failure                               |
| WDT     | NETWORK_REGISTER   | Watchdog timeout while trying to register on a network              | No response, or (temporarily) no network coverage, or SIM                                            |
| WDT     | APN_OPEN           | Watchdog timeout while trying to find an internet access point      | No response, or APN access point name wrong                                                          |
| WDT     | APN_LOGIN          | Watchdog timeout while trying to login to the internet access point | No response, or APN user or password wrong, or authentication failure                                |

|     |                |                                                                                              |                                                                |
|-----|----------------|----------------------------------------------------------------------------------------------|----------------------------------------------------------------|
|     |                |                                                                                              |                                                                |
| WDT | SERVER_LOGIN   | Watchdog timeout while trying to login to the Email/FTP/TCP/ HTTP server                     | No response, or server not available, or credentials wrong     |
| WDT | FILE_OPEN      | Watchdog timeout while trying to open a file on the FTP server                               | No response, or file handling error on the server              |
| WDT | DATA_SENDING   | Watchdog timeout while sending data to the Email/FTP/TCP/ HTTP server                        | No response, or unexpected network disruption, or server error |
| WDT | TCP_RESPONSE   | Watchdog timeout while waiting for acknowledge from the TCP/HTTP server                      | No response, or unexpected network disruption, or server error |
| WDT | DATA_END       | Watchdog timeout while trying to disconnect from the Email/FTP/TCP/ HTTP server connection   | No response, or unexpected network disruption, or server error |
| WDT | "STATE number" | Modem state machine step where the watchdog timeout occurred                                 | No response                                                    |
| ERR | "Driver name"  | Shows the driver name were an error occurred, with if applicable some additional information | Sensor defect, or unknown failure                              |
| ERR | MODEM_INIT     | Error while initializing Modem                                                               | No SIM, or SIM not detected, or PIN on                         |

|              |                  |                                                               |                                                                                                           |
|--------------|------------------|---------------------------------------------------------------|-----------------------------------------------------------------------------------------------------------|
|              |                  |                                                               | SIM                                                                                                       |
| ERR          | NETWORK_REGISTER | Error while trying to register on a network                   | (Temporarily) no network coverage, or SIM subscription failure (inactive/invalid/blocked or black listed) |
| ERR          | APN_OPEN         | Error while trying to find an internet access point           | APN access point name wrong                                                                               |
| ERR          | APN_LOGIN        | Error while trying to login to the internet access point      | APN user or password wrong, or authentication failure                                                     |
| ERR          | SERVER_LOGIN     | Error while trying to login to the Email/FTP/TCP/HTTP server  | Server not available or credentials wrong                                                                 |
| ERR          | FILE_OPEN        | Error while trying to open a file on the FTP server           | File handling error on the server                                                                         |
| ERR          | DATA_SENDING     | Error while sending data to the Email/FTP/TCP/HTTP server     | Unexpected network disruption, or server error                                                            |
| ERR          | TCP_RESPONSE     | Error while waiting for acknowledge from the TCP/HTTP server  | Unexpected network disruption, or server error                                                            |
| ERR          | DATA_END         | Error trying to disconnect from the Email/FTP/TCP/HTTP server | Unexpected network disruption, or server error                                                            |
| ERR          | "STATE number"   | Modem state machine error                                     | Unknown                                                                                                   |
| SMS_SEND_ERR |                  | An error occurred while sending SMS                           | See the Modem ERR/WDT message                                                                             |

|               |                        |                                                              |                                                             |
|---------------|------------------------|--------------------------------------------------------------|-------------------------------------------------------------|
|               |                        |                                                              | before for more details                                     |
| SMS_SEND_OK   |                        | Sending of the SMS was successful                            |                                                             |
| SMS_RECV_ACVA | "Phone number"         | An ACVA SMS was received                                     |                                                             |
| SMS_RECV_ERR  | "Phone number"         | An invalid SMS was received                                  |                                                             |
| CNT_RESET     | "digital sensor name"  | Shows the reset of the pulse counter                         | When reset at midnight option is on, or after manual change |
| STR           | "Driver name;raw data" | Shows the raw data log                                       | When this option is enabled (generic serial string and GPS) |
| TIME_FIX      | " +/- number of sec"   | Shows the number seconds the internal clock was adjusted     | After a NTP time synchronization                            |
| TIME_FIX      | "Summer time started"  | Shows that the clock is adjusted to the start of summer time | When summer time (daylight saving) option is enabled        |
| TIME_FIX      | "Summer time ended"    | Shows that the clock is adjusted to the end of summer time   | When summer time (daylight saving) option is enabled        |
| ALARM_SET     | "Code;limit;value"     | Shows the parameter code, alarm limit and actual value       | When the alarm is raised                                    |
| ALARM_RESET   | "Code;limit;value"     | Shows the parameter code, alarm limit and actual value       | When the alarm is cleared                                   |